



**Draft TENDER
For**

Name of Work: Providing new sampling points at Bhandup Complex

STANDARD BID DOCUMENT

Website: portal.BMC.gov.in/tenders

Office of: Dy. Hydraulic Engineer (Bhandup Complex),
2nd floor, Administration building,
Bhandup Complex,
Durgah Road, Mulund (w),
Mumbai – 400 082

Prepared By

Checked by

Verified By

Approved by

S.E.(F.M.)B.C.

A. E. (F.M.)B.C.

E. E. (T.C.W.) B.C.

Dy H. E. (B. C)

INDEX

SECTION N	DESCRIPTION	PG- NO
1	E-TENDER NOTICE	3
2	ELIGIBILITY CRITERIA	7
3	DISCLAIMER	11
4	INTRODUCTION	14
5	E-TENDER ONLINE SUBMISSION PROCESS	17
6	INSTRUCTIONS TO APPLICANTS	21
7	SCOPE OF WORK	50
8	BILL OF QUANTITIES	52
9	GENERAL CONDITIONS OF CONTRACT	56
10	SPECIFICATION & SELECTION OF MATERIAL	102
11	FRAUD AND CORRUPT PRACTICES	110
12	PRE-BID MEETING	113
13	LIST OF APPROVED BANKS	115
14	APPENDIX	119

SECTION - I

E - TENDER NOTICE

BRIHANMUMBAI MUNICIPAL CORPORATION

HYDRAULIC ENGINEER'S DEPARTMENT

No. Dy.H.E./B.C./24/08/ODN dtd.05.06.2024

E- TENDER No.2024_MCGM_1039758_1

E-TENDER NOTICE

Sub : Providing new sampling points at Bhandup Complex

The BRIHANMUMBAI MUNICIPAL CORPORATION (BMC) invites e-tender on **percentage rate** basis to appoint Contractor for the aforementioned work from contractors of repute, multidisciplinary engineering organizations i.e. eminent firm, Proprietary / Partnership Firms / Private Limited Companies / Public Limited Companies / Companies registered under the Indian companies' act 2013, the contractors registered with the Municipal Corporation of Greater Mumbai, (BMC) **in Class 'B1' as per new registration** and / or firms dealing in the line and from the contractors / firms equivalent and superior classes registered in Central or State Government / Semi Govt. Organization / Central or State Public Sector Undertakings, will be allowed subject to condition that, the contractors who are not registered with BMC will have to apply for registering their firm within three months time period from the award of contract, otherwise their Bid Security i.e. E.M.D (Earnest Money Deposit) will be forfeited / recovered and an amount equal to Registration Fee of respective class will be recovered as penalty.

Bidding Process will comprise of THREE stages.

The tender form can be downloaded from e-procurement system of Government of Maharashtra (Mahatenders) (<https://mahatenders.gov.in>). The scrutiny fees of Rs.3300/- +18%GST as mentioned in Header data shall be paid at BMC's CFC centre by obtaining challan from BMC office before opening of packet C.

The applicants not registered with BMC are mandated to get registered (Vendor Registration) with BMC. Interested bidders should have valid Class III digital signature certificate (DSC) obtained from any licensed certifying authority. Interested bidders should follow the manuals available on Mahatenders Portal (<https://mahatenders.gov.in>). Vendors can get digital signature from any one of the Certifying Authorities (CA's) licensed by controller of certifying authorities namely, Safes crypt, IDRBT, National informatics center, TCS, CUSTOMS, MTNL, GNFC and e- Mudhra, CA.

Name and location of work	Contract period	Estimated Cost of Project
Providing new sampling points at Bhandup Complex	04 Months (excluding Monsoon)	Rs.19,92,310/- (Excluding GST)

In terms of the 3 stage system of e-tendering, a Bidder will be required to deposit, along with its Bid, an Earnest Money Deposit of **Rs. 20,000/- (Rupees Twenty Thousand only)** (the "EMD"), refundable in accordance to the relevant clause of bid document, from the Bid Due Date, except in the case of the selected Bidder whose Bid Security / EMD shall be retained. The Bidders will have to provide Earnest Money Deposit through the payment gateways while submitting the bids. The Bid shall be summarily rejected if it is not accompanied by the Earnest Money Deposit. The e-tender is available on e-procurement system of Government of Maharashtra (Mahatenders) (<https://mahatenders.gov.in>) as mentioned in the Header Data of the tender.

As per THREE Packet systems, the document for Packet A & B is to be uploaded by the bidder in vendors' document online in Packet A, B. Packet A, B & C shall be opened on dates as mentioned in header data. All the responsive and eligible bidders if they so wish can be present at the time of opening of bids, in the office of Dy. Hydraulic Engineer (B.C.). The Packet C shall be opened if bids submission in Packet A & B satisfies / includes all the requirements and same are found acceptable to the Authority.

The Municipal Commissioner reserves the right to reject all or any of the e- tender(s) without assigning any reasons at any stage.

The dates and time for submission and opening the bids are as shown in the Header Data. If there are any changes in the dates the same will be displayed on e-procurement system of Government of Maharashtra (Mahatenders) (<http://mahatenders.gov.in>)

The Applicants interested for the above referred works may contact the Dy. Hydraulic Engineer (B. C.) at the following address on any working day during office hours.

Office of the : Dy. Hydraulic Engineer (Bhandup Complex),
2nd floor, Administration building,
Bhandup Complex, Durgah Road,
Mulund (w), Mumbai – 400 082

The applicants may wish to visit the site under reference located at Bhandup complex as part of Mulund West, Mumbai and can collect the information of the present status from the department who have invited the bids.

BMC reserves the rights to accept any of the application or reject any or all the application received for above works, without assigning any reasons thereof. The information regarding above subject matter is available on e-procurement system of Government of Maharashtra (Mahatenders) (<http://mahatenders.gov.in>).

Sd/-

**Executive Engineer(T.C.W)
Bhandup Complex.**

HEADER DATA

Tender Document No	:	2024_MCGM_1039758_1
Name of Organization	:	BRIHANMUMBAI MUNICIPAL CORPORATION
Subject	:	Providing new sampling points at Bhandup Complex
Scrutiny fees	:	Rs. 3300/- + 18 % GST
Cost of E-Tender (Estimated Cost)	:	Rs.19,92,310/-(Excluding GST)
Bid Security Deposit / EMD	:	Rs.20,000/-
Date of issue and sale of tender	:	09/07/2024 from 11:00 Hrs
Last date & time for sale of tender & Receipt of Bid Security Deposit	:	23/07/2024 upto 16:00 Hrs
Submission of Packet A, B & Packet C (Online)	:	23/07/2024 upto 16:00 Hrs
Pre-Bid Meeting	:	at 12.15 PM Venue : Hydraulic Engineer, 1st floor, Engineering Hub Building, Dr. E. Mozes Road, worli Naka, Mumbai 400018
Opening of Packet A	:	25/07/2024 after 16:01 Hrs.
Opening of Packet B	:	25/07/2024 after 16:01 Hrs.
Opening of Packet C	:	01/08/2024 after 15:00 Hrs.
Address for communication	:	Office of the:- Dy.H.E.(B.C.)'s office BMC, Administration Building, 2 nd floor, Khindipada, Dargah Road, Bhandup Complex, Mulund (West), Mumbai 400082 , Fax-022 25658505
Venue for opening of bid	:	On line in Dy. Hydraulic Engineer (Bhandup Complex)'s office.

Note: The tenderers shall have to pay scrutiny fee with GST. It is to be paid at CFC centre by obtaining challan from this office before opening of packet C.

This tender document is not transferable.

The BMC reserves the rights to accept any of the application or reject any or all the application received for above subject without assigning any reason thereof.

Sd/-

**Executive Engineer(T.C.W)
Bhandup Complex.**

SECTION 2
ELIGIBILITY(POST
QUALIFICATION)
CRITERIA

1 Regular, Routine and Maintenance works:

1.1 Technical Capacity

The tenderer(s) in their own name should have satisfactorily completed the work of similar nature BMC / Semi Govt. / Govt. & Public Sector Organizations during **last seven (7) years** ending last day of month previous to the one in which bids are invited as a prime Contractor (or as a nominated sub-Contractor, where the subcontract had involved similar nature of work as described in the scope of works in this bid document, provided further that all other qualification criteria are satisfied)

a) **Three similar completed** works involves **each** of value not less than **Rs. 5,97,993/-**

OR

b) **Two similar completed** works **each** of value not less than **Rs. 6,97,659/-**

OR

c) **One similar completed** work of value equal and or not less than **Rs. 9,96,655/-**

The value of completed works shall be brought to current costing level by enhancing the actual value of work at compound rate of 10 % per annum; calculated from the date of completion to last date of receipt of applications for tenders.

1.2 Financial Capacity

Achieved an average annual financial turnover as certified by 'Chartered Accountant' (~~in all classes of civil engineering construction works only~~) shall be **Rs.5,97,993/- in last three (3) financial years** immediately preceding the Financial Year in which bids are issued.

The value of completed works shall be brought to current costing level by enhancing the actual value of work at compound rate of 10 % per annum; calculated from the date of completion to the date of issue of tenders.

1.3 Similar Experience:

"For assessing the technical capacity of Regular, Routine and Maintenance works; Similar work shall mean, SITC/repairing of pump/piping/fabrication work *in BMC / Semi Govt. / Govt. / Public Sector organizations*

Past performance certificates, including the work order number and date, cost of the work, contract period, etc. shall be annexed by the bidder while submitting the offer.

~~2 For Original and New construction works~~

~~2.1 Technical Capacity (Project Experience)~~

~~The tenderer(s) in their own name should have satisfactorily executed the work of similar nature BMC / Semi Govt. / Govt. & Public Sector Organizations during last seven (7) years ending last day of month previous to the one in which bids are invited as a prime Contractor (or as a nominated sub-Contractor, where the subcontract had involved similar nature of work as described in the scope of works in this bid document, provided further that all other qualification criteria are satisfied)~~

- ~~a) Three similar completed works or currently executing three works of similar nature each costing 30% of estimated cost.* OR~~
- ~~b) Two similar completed works or currently executing two works of similar nature each costing 40% of estimated cost.* OR~~
- ~~c) One completed work or currently executing one work of similar nature of aggregate 60% of estimated cost.*~~

~~The value of executed works shall be brought to current costing level by enhancing the actual value of work at compound rate of 10 % per annum; calculated from the date of completion to last date of receipt of applications for tenders.~~

~~*In case of ongoing works to be considered, the bidder must have received payment bills of 80% of the contract sum for the work/works executed last day of month previous to the one in which bids are invited.~~

~~2.2 Financial Capacity~~

~~Achieved a average annual financial turnover as certified by 'Chartered Accountant' (in all classes of civil engineering construction works only) equal to 30% of the estimated cost of work in last three (3) financial years immediately preceding the Financial Year in which bids are invited.~~

- ~~● To ascertain this, tenderer(s) shall furnish /upload the financial statement (Audited balance sheet) duly certified by Chartered Accountant.~~
- ~~● The turnover can be enhanced by 10% every year to bring the present level.~~

~~3.1 Bid Capacity:~~

~~The bid capacity of the prospective bidders will be calculated as under:-~~

~~Assessed Available Bid Capacity = $(A * N * 2 - B)$~~

~~Where,~~

~~A = Maximum value of Civil Engineering works executed in any one year (year means Financial year) during **the last five years** (updated to the price level of the Financial year in which bids are received at a rate of 10% per year) taking into account the completed as well as works in progress.~~

~~N = Number of years prescribed for completion of the Project/Works, **excluding monsoon period**, for which these bids are being invited. (E.g. 7 months = 7/12 year) For every intervening monsoon 0.33 shall be added to N.~~

~~**B** = Value of existing commitments (only allotted works) on the last date of submission of bids as per bidding document and on-going works to be completed during the period of completion of the Project/Works for which these bids are being invited.~~

~~Note: The statement showing the value of existing commitments and on-going works as well as the stipulated period of completion remaining for each of the works listed should be attached along with certificates duly signed by the Engineer in Charge, not below the rank of an Executive Engineer or equivalent.~~

Even though the bidders meet the above qualifying criteria, they are subject to be disqualified if they have:

- made misleading or false representation in the forms, statements and attachments submitted in proof of the qualification requirements; and / or
- Record for poor performance such as abandoning the works, not properly completing the contract, inordinate delays in completion, litigation history, or financial failures etc

SECTION 3
DISCLAIMER

DISCLAIMER

The information contained in this e-tender document or provided to Applicant(s), whether verbally or in documentary or any other form, by or on behalf of the BRIHANMUMBAI MUNICIPAL CORPORATION (BMC), hereafter also referred as “The Authority “, or any of its employees or advisors, is provided to Applicant(s) on the terms and conditions set out in this e-tender and such other terms and conditions subject to which such information is provided.

This e-tender includes statements, which reflect various assumptions and assessments arrived at by the BRIHANMUMBAI MUNICIPAL CORPORATION (BMC) in relation to the Project. Such assumptions, assessments and statements do not purport to contain all the information that each Applicant may require. This e-tender may not be appropriate for all persons, and it is not possible for the BRIHANMUMBAI MUNICIPAL CORPORATION (BMC), its employees or advisors to consider the investment objectives, financial situation and particular needs of each party who reads or uses this e-tender. The assumptions, assessments, statements and information contained in this e-tender may not be complete, accurate, adequate or correct. Each Applicant should therefore, conduct its own investigations and analysis and should check the accuracy, adequacy, correctness, reliability and completeness of the assumptions, assessments, statements and information contained in this e-tender and obtain independent advice from appropriate sources.

Information provided in this e-tender to the Applicant(s) is on a wide range of matters, some of which may depend upon interpretation of law. The information given is not intended to be an exhaustive account of statutory requirements and should not be regarded as a complete or authoritative statement of law. The BRIHANMUMBAI MUNICIPAL CORPORATION (BMC) accepts no responsibility for the accuracy or otherwise for any interpretation or opinion on law expressed here.

The BRIHANMUMBAI MUNICIPAL CORPORATION (BMC), its employees and advisors make no representation or warranty and shall have no liability to any person, including any Applicant or Bidder, under any law, statute, rules or regulations or tort, principles of restitution or unjust enrichment or otherwise for any loss, damages, cost or expense which may arise from or be incurred or suffered on account of anything contained in this e-tender or otherwise, including the accuracy, adequacy, correctness, completeness or reliability of the e-tender and any assessment, assumption, statement or information contained therein or deemed to form part of this e-tender or arising in any way with pre-qualification of Applicants for participation in the Bidding Process. The BRIHANMUMBAI MUNICIPAL CORPORATION (BMC) also accepts no liability of any nature whether resulting from negligence or otherwise howsoever caused arising from

reliance of any Applicant upon the statements contained in this e-tender.

The BRIHANMUMBAI MUNICIPAL CORPORATION (BMC) may, in its absolute discretion but without being under any obligation to do so, update, amend or supplement the information, assessment or assumptions contained in this e-tender.

The issue of this e-tender does not imply that the BRIHANMUMBAI MUNICIPAL CORPORATION (BMC) is bound to select and short-list pre-qualified Applications for Bid Stage or to appoint the selected Bidder or Concessionaire, as the case may be, for the Project and the BRIHANMUMBAI MUNICIPAL CORPORATION (BMC) reserves the right to reject all or any of the Applications or Bids without assigning any reasons whatsoever.

The Applicant shall bear all its costs associated with or relating to the preparation and submission of its Application including but not limited to preparation, copying, postage, delivery fees, expenses associated with any demonstrations or presentations which may be required by The BRIHANMUMBAI MUNICIPAL CORPORATION (BMC) or any other costs incurred in connection with or relating to its Application. All such costs and expenses will remain with the Applicant and the BRIHANMUMBAI MUNICIPAL CORPORATION (BMC) shall not be liable in any manner whatsoever for the same or for any other costs or other expenses incurred by an Applicant in preparation or submission of the Application, regardless of the conduct or outcome of the Bidding Process.

SECTION 4

INTRODUCTION

INTRODUCTION

4.1. Background

The BRIHANMUMBAI MUNICIPAL CORPORATION covers an area of 437.71 sq. kms. with a population of 1.24 Crores as per census of 2011. The metropolis accounts major portion of India's international trade and government's revenue, from being one of the foremost centers of education, science and technological research and advancement.

The Mumbai Metropolis has historic tradition of strong civic activism dedicated to the cause of a better life for all its citizens. And it's the BRIHANMUMBAI MUNICIPAL CORPORATION (BMC), hereafter called the "corporation", the primary agency responsible for urban governance in Greater Mumbai.

BMC (The Authority) is one of the largest local self-governments in the Asian Continent. In observance of historic traditions of strong civic activism, with the change in time and living conditions to match with the urbanization, BMC has mainly focused in providing almost all kinds of engineering services viz, Hydraulics, storm water drain, sewerage, water supply projects, roads, bridges, solid waste management, and environmental services. Beside this, the BMC is also providing dedicated services in various segments such as Health, Primary Education as well as the construction and maintenance of Public Markets and Slaughter Houses.

BMC is an organization having different departments, right from engineering depts. to health depts. Moreover we have other dept. like education, market, fire brigade dept. and other such departments where quite a good number of staff members are working.

Bhandup Complex Water Treatment Plant is situated in vicinity of Sanjay Gandhi National Park and spread over about 365 acres area. This Water Treatment Plant caters the need water supply to Mumbai Region. It treats and supply water to the tune of 1910 MLD.

4.2 Scope of Work

BMC is primarily an organization, which in the interest of citizens and with the speed of urbanization deals with the variety of the infrastructure services and delivered to the public by different departments like Water Supply Projects, Sewerage Projects, Hydraulics, Storm Water Drain / Roads and bridges and Building Construction etc.

The scope of the work involves "Providing new sampling points at Bhandup Complex" as below-

SECTION 5

E-TENDERING ONLINE

SUBMISSION PROCESS

E-TENDERING ONLINE SUBMISSION PROCESS

E-TENDERING ONLINE SUBMISSION PROCESS

The terminology of e-Tendering is solely depending upon policies in existence, guidelines and methodology adopted since decades. ~~The SRM is only change in process of accepting and evaluation of tenders in addition to manual. The SAP module to be used in this E-tendering is known as Supplier Relationship Module (SRM).SRM is designed and introduced by ABM Knowledge ware Ltd. who will assist BMC in throughout the tendering process for successful implementation.~~

NOTE: This tendering process is covered under Information Technology ACT & Cyber Laws as applicable

(1) In e-tendering process some of the terms and its definitions are to be read as under wherever it reflects in online tendering process.

- Start Date read as “Sale Date”
- End Date read as “Submission Date”
- Supplier read as “Contractor / bidder”
- Vendor read as “Contractor / bidder”
- Vendor Quotation read as “Contractors Bid / Offer”
- Purchaser read as “Department / BMC”

I. Before entering in to online tendering process, the bidders should complete the registration process so as to get User ID for E-tendering links. For this, the bidders can access through Supplier registration via BMC Portal.

There are two methods for this registration :(II and III)

II. Transfer from R3 (registered contractors with BMC) to SRM

- a. Contractors already registered with BMC will approach to Vendor Transfer cell.
- b. Submit his details such as (name, vendor code, address, registered Email ID, pan card etc.) to Vendor transfer cell.
- c. BMC authority for Vendor Transfer, transfers the Vendor to SRM application from R3 system to SRM system.
- d. Transferred Vendor receives User ID creation link on his supplied mail Id.
- e. Vendor creates his User ID and Password for e-tendering applications by accessing link sent to his mail ID.

III. Online Self Registration (Temporary registration for applicant not registered with BMC)

- a. Vendor fills up Self Registration form via accessing BMC portal.
- b. Vendor Transfer cell (same as mentioned above) accesses Supplier Registration system and accepts the Vendor request.
- c. Accepted Vendor receives User ID creation email with Link on his supplied mail Id.
- d. Vendor creates his User ID and Password for e-tendering application.

CONTRACTORS BIDDING: Applicant will Quote & Upload Tender Documents (Vendor
IV. ~~please follow the instruction manual of New E-tendering system Hana (SRM 7.0) during quote and upload tender documents.~~) available in BMC portal.

1. ~~Access e-tender link of SRM Portal~~
2. Log in with User ID and Password
3. Selects desired Bid Invitation (he wants to bid)
4. ~~To download tender documents bidders will have to pay online Tender fee. The same can be done by accessing Pay Tender Fees option. By this one will be able to pay Tender fee through Payment Gateway. If transaction successful bidders can register his interest to participate. Without Registration one cannot quote for the Bid / Tender.~~
5. ~~Applicant will download Tender Documents from Information from purchaser tab by accessing Purchaser document folder through collaboration 'C' folder link.~~
6. Applicant will upload Packet 'A' related and Packet 'B' related Documents in Packet 'A' and Packet 'B' folder respectively ~~by accessing these folders through "My Notes" Tab and collaboration folder link.~~
7. All the documents uploaded have to be digitally signed and saved. bidders can procure there digital signature from any certified CA's in India.
8. Bid security deposit / EMD & ASD, if applicable, should be paid online as mentioned in tender.
9. For commercial details (in Packet C) bidders will fill data in Item Data tab in Service Line Item via details and quotes his offer. ~~"Percentage Variation" (i.e.% quoted) figure. (If entered '0' it will be treated as at par. By default the value is zero only.~~
10. Applicants to check the bid, digitally signs & save and submit his Bid Invitation.
11. ~~Applicants can also save his uploaded documents/commercial information without submitting the BID for future editing through 'HOLD' option.~~
12. ~~Please note that "Hold" action do not submit the Bid.~~
13. Applicants will receive confirmation once the Bid is submitted.
14. Bid creator (BMC) starts Bid Opening for Packet A after reaching End Date and Time and Bid Evaluation process starts.

As per Three Packet system, the document for Packet A & B are to be uploaded by the tenderer in 'Vendor's document' online in Packet A & B. Before purchasing/ downloading the tender copy, tenderer may refer to post- Qualification criteria mentioned in e-Tender Notice.

The tenderer shall pay the EMD / Bid Security through payment gateways before submission of Bid and shall upload the screenshot of receipt of payment in Packet 'A' instead of paying the EMD at any of the CFC centers in BMC Ward Offices.

The e-tender is available on BMC portal, <https://mahatenders.gov.in>, as mentioned in the Header Data of the tender. The tenders duly filled in should be uploaded and submitted online on or before the end date of submission. The Packet 'A', Packet 'B' & Packet 'C' of the tenderer will be opened as per the time-table shown in the Header Data in the office of the Dy. H.E. (Bhandup Complex), BMC, 2nd floor, Admin. Building, Khindipada, Mulund West, Mumbai -400082.

The Municipal Commissioner reserves the right to reject all or any of the e-Tender(s) without assigning any reason at any stage. The dates and time for submission and opening the tenders are as shown

in the Header Data. If there are any changes in the dates the same will be displayed on the government Portal (<https://mahatenders.gov.in>).

SECTION 6
INSTRUCTIONS TO
APPLICANTS

INSTRUCTIONS TO APPLICANTS

6.1 Scope of Application

The Authority wishes to receive Applications for Qualification in order to SELECT experienced and capable Applicants for the Bid Stage.

6.2 Eligibility of Applicants

The BRIHANMUMBAI MUNICIPAL CORPORATION (BMC) invites e-tender on item rate basis to appoint Contractor for the aforementioned work from contractors of repute, multidisciplinary engineering organizations i.e. eminent firm, Proprietary / Partnership Firms / Private Limited Companies / Public Limited Companies / Companies registered under the Indian companies' act 2013, the contractors registered with the Municipal Corporation of Greater Mumbai, (BMC) in **Class 'B1' as per new registration** and / or firms dealing in the line and from the contractors / firms equivalent and superior classes registered in Central or State Government / Semi Govt. Organization/Central or State Public Sector Undertakings, will be allowed subject to condition that, the contractors who are not registered with BMC will have to apply for registering their firm within three months time period from the award of contract, otherwise their Bid Security i.e. E.M.D (Earnest Money Deposit) will be forfeited / recovered and an amount equal to Registration Fee of respective class will be recovered as penalty.

To be eligible for pre-qualification and short-listing, an Applicant shall fulfill the following conditions of eligibility:

1 For Regular, Routine and Maintenance works:

1.1 Technical Capacity

The tenderer(s) in their own name should have satisfactorily completed the work of similar nature BMC / Semi Govt. / Govt. & Public Sector Organizations during **last seven (7) years** ending last day of month previous to the one in which bids are invited as a prime Contractor (or as a nominated sub-Contractor, where the subcontract had involved similar nature of work as described in the scope of works in this bid document, provided further that all other qualification criteria are satisfied)

a) **Three similar completed** works involves **each** of value not less than **Rs. 5,97,993/-**

OR

b) **Two similar completed** works **each** of value not less than **Rs. 6,97,659/-**

OR

c) **One similar completed** work of value equal and or not less than **Rs. 9,96,655/-**

The value of completed works shall be brought to current costing level by enhancing the actual value of work at compound rate of 10 % per annum; calculated from the date of completion to last date of receipt of applications for tenders.

1.2 Financial Capacity

Achieved an average annual financial turnover as certified by 'Chartered Accountant' ~~(in all classes of civil engineering construction works only)~~ shall be **Rs.5,97,993/- in last three (3) financial years** immediately preceding the Financial Year in which bids are issued.

The value of completed works shall be brought to current costing level by enhancing the actual value of work at compound rate of 10 % per annum; calculated from the date of completion to the date of issue of tenders.

1.3 Similar Experience:

"For assessing the technical capacity of Regular, Routine and Maintenance works; Similar work shall mean, SITC/repairing of pump/piping/fabrication work *in BMC / Semi Govt. / Govt. / Public Sector organizations.*

2 For Original and New construction works,

2.1 ~~Technical Capacity (Project Experience)~~

~~The tenderer(s) in their own name should have satisfactorily executed the work of similar nature BMC / Semi Govt. / Govt. & Public Sector Organizations during last seven (7) years ending last day of month previous to the one in which bids are invited as a prime Contractor (or as a nominated sub-Contractor, where the subcontract had involved similar nature of work as described in the scope of works in this bid document, provided further that all other qualification criteria are satisfied)~~

~~a) Three similar completed works or currently executing three works of similar nature each costing 30% of estimated cost.*~~

~~OR~~

~~b) Two similar completed works or currently executing two works of similar nature each costing 40% of estimated cost.*~~

~~OR~~

~~c) One completed work or currently executing one work of similar nature of aggregate 60% of estimated cost.*~~

~~The value of executed works shall be brought to current costing level by enhancing the actual value of work at compound rate of 10 % per annum; calculated from the date of completion to last date of receipt of applications for tenders.~~

~~*In case of ongoing works to be considered, the bidder must have received payment bills of 80% of the contract sum for the work/works executed last day of month previous to the one in which bids are invited.~~

2.2 Financial Capacity

~~Achieved a average annual financial turnover as certified by 'Chartered Accountant' (in all classes of civil engineering construction works only) equal to 30% of the estimated cost of work in last three (3) financial years immediately preceding the Financial Year in which bids are invited.~~

~~● To ascertain this, tenderer(s) shall furnish /upload the financial statement (Audited balance sheet) duly certified by Chartered Accountant.~~

~~● The turnover can be enhanced by 10% every year to bring the present level.~~

C) Bid Capacity:

~~The bid capacity of the prospective bidders will be calculated as under: Assessed Available Bid Capacity = (A * N * 2 - B)~~

~~Where,~~

~~A = Maximum value of Civil Engineering works executed in any one year (year means Financial year) during the last five years (updated to the price level of the Financial year in which bids are received at a rate of 10% per year) taking into account the completed as well as works in progress.~~

~~N = Number of years prescribed for completion of the Project/Works, **excluding monsoon period**, for which these bids are being invited. (E.g. 7 months = 7/12 year) For every intervening monsoon 0.33 shall be added to N.~~

~~B = Value of existing commitments (only allotted works) on the last date of submission of bids as per bidding document and on-going works to be completed during the period of completion of the Project/Works for which these bids are being invited.~~

~~Note: The statement showing the value of existing commitments and on-going works as well as the stipulated period of completion remaining for each of the works listed should be attached along with certificates duly signed by the Engineer in Charge, not below the rank of an Executive Engineer or equivalent.~~

~~Even though the bidders meet the above qualifying criteria, they are subject to be disqualified if they have:~~

~~➤ made misleading or false representation in the forms, statements and attachments submitted in proof of the qualification requirements; and/or~~

~~➤ Record for poor performance such as abandoning the works, not properly completing the contract, inordinate delays in completion, litigation history, or financial failures etc~~

D. Equipment Capabilities as required for this work

- a) **Regular and Routine works:** The successful bidder will make the arrangements of the required equipment on the day of commencement or with respect to the progress of the work in phases, as per the instructions of site in charge. ~~The successful bidder and, to that effect he will ensure commitment on an undertaking on Rs.500 stamp paper to be submitted along with the Bid in Packet B.~~ However, this condition in no way shall dilute the respective condition in Registration Rules of BMC.

b) ~~New and Original Works~~: The bidder should, undertake their own studies and furnish with their bid, a detailed construction planning and methodology supported with assessment study of requirements of equipment / plants and machineries to allow the employer to review their proposal. The bidder will ensure his commitment to make the arrangements of the required equipment on the day of commencement or with respect to the progress of the work in phases, as per the instructions of site in charge on an undertaking on Rs.500 stamp paper to be submitted along with the Bid in Packet B. However, this condition in no way shall dilute the respective condition in Registration Rules of BMC.

Note:-

1. Bidders shall submit the undertaking for equipment capability and other undertakings as such on a single Rs.500/- stamp paper.
2. Insistence of availability of equipment/plants at a particular distance from site should not be made in the tender documents.

6.3 Classes available for Civil Contractors (As per old registration rules)

<i>Category</i>	<i>Description of work</i>
Building—C-I	Building & allied works, pile foundation, precast or cast in situ concrete works, diaphragm walls, ground anchors and allied works, water proofing, leak proofing of various types of structures.
Bridges—C-II	Bridges including road over bridges, flyover, foot over bridges, subways & culverts.
Roads—C-III	Road works of various types including storm water drains culverts and training/ de-silting of nallas, underground storm water drains.
Water Supply—C-IV	Laying of water mains, rising mains, water pumping stations, reservoirs, head works.
Sewerage—C-V	Laying of sewers, rising main & underground storm water drains, sewage pumping stations, treatment plants, outfalls etc.

6.4 Class available according to the limits of works, amount of solvency, registration fees & amount of standing deposit prescribed for each class (As per old registration rules)-

<i>Class</i>	<i>Works—limit</i>	<i>Solvency amount</i>	<i>Scrutiny fees</i>	<i>Registration fees</i>	<i>Renewal fees</i>	<i>Standing deposit</i>
	<i>Rs</i>	<i>Rs In Laacs</i>	<i>Rs</i>	<i>Rs</i>	<i>Rs</i>	<i>Rs</i>
AA	Without limit	60	2000	4000	2000	7,50,000.00
A	upto 3 Crores	30	2000	4000	2000	4,50,000.00
B	upto 1 Crore	20	1000	2000	1000	3,00,000.00
C	upto 50 Laacs	15	1000	2000	1000	1,50,000.00
D	upto 25 Laacs	10	1000	2000	1000	1,12,500.00
E	upto 10 Laacs	5	1000	2000	1000	45,000.00

6.5 MINIMUM FINANCIAL AND ORGANIZATIONAL REQUIREMENTS FOR CIVIL ENGINEERING DISCIPLINE AS PER REFRAMED RULES

Sr. No	Class	Upper limit of Tendering	Minimum Solvency	Total Turn-Over in Last 3-Years	Cost of Single Work Completed within Last 3-years	No. of Civil Engineers Employee
1	2	3	4	5	6	7
1	I(A)	Without Limit	200	4000	1500	4 Graduate with 5 years or 1 Graduate with 5 years and 5 Diploma Holder with 7 years experience.
2	I(B)	2500	175	2500	750	3 Graduate with 5 years or 1 Graduate with 5 years and 4 Diploma Holder with 7 years experience.
3	I(C)	1500	150	1500	300	3 Graduate with 5 years or 1 Graduate with 5 years and 4 Diploma Holder with 7 years experience.
4	II	750	100	750	150	2 Graduate with 3 years or 1 Graduate with 3 years and 3 Diploma Holder with 5 years experience.
5	III	300	75	300	90	2 Graduate with 3 years or 1 Graduate with 3 years and 2 Diploma Holder with 5 years experience.
6	IV	150	40	150	50	1 Graduate with 1 year or 1 Diploma Holder with 3 years experience.
7	IV(A)	90	25	90	30	1 Graduate with 1 year or 1 Diploma Holder with 3 years experience.
8	V	50	15	50	15	1 Graduate with 1 year or 1 Diploma Holder with 3 years experience.
9	V(A)	30	8	0	0	1 Fresh Graduate or 1 Fresh Diploma Holder.
10	VI	15	2	0	0	1 Fresh Graduate or 1 Fresh Diploma Holder.
11	VII	10	1	0	0	1 Fresh Graduate or 1 Fresh Diploma Holder.
12	VIII	5	0.5	0	1 Fresh Graduate or 1 Fresh Diploma Holder.
13	IX	3	0.25	1 Fresh Graduate or 1 Fresh Diploma Holder.

Note:-

1) A Solvency Certificate registered beyond 12 months from the date of its issue will not be considered. Certificate of Solvency (in Hindi/Marathi/English) shall be obtained from scheduled or

Nationalise Bank, in the name of the applicant/Firm/Company only.

2) Turn-over shall be supported with work completion/performance certificate of civil works only. In case of works carried out in private organization, T.D.S. Certificate is essential and certificate from License Architect is necessary.

3) Cost of single work criteria will be governed as given in below table

6.6 SINGLE WORK CRITERIA (Rs. In Lakhs) (As per New registration rules)

Single work criteria(Applicant has to fulfill one of the following criteria)					
Sr. No.	Class	Upper limit of Tendering	Minimum Cost of Single Work Completed (within Last 3 years)	Cost of Two Works Completed costing not less than (Within Last 3 years)	Cost of Three Works Completed costing not less than (Within Last 3 years)
1	2	3	4	5	6
1	I(A)	Without Limit	1500	750	500
2	I(B)	2500	750	400	250
3	I(C)	1500	300	150	100
4	H	750	150	75	50
5	HH	300	90	50	30
6	IV	150	50	25	20
7	IV(A)	90	30	15	10
8	V	50	15	8	5

6.7 Equipment Capabilities as required for this work

6.8 Equipment Capability:

Sr. No	Equipments owned/access to	Requirements (No.)		
		Regular and Routine works	New and Original Works	For other special works
1	2	3	4	5
01	Pumps for dewatering	1(5 BHP)	2(5HP)	-
02	Submersible pumps for dewatering	2(5 BHP)	2(5 BHP)	-
03	Rock breaker with compressor	1	1	-
04	Pipe cutter	2	2	-
05	Ratchet Drilling machine.	2	2	-
06	Roller Vibratory Min. 10T	1	2	-
07	Welding set.	2	2	-
08	Compressor	2	2	-

09	Transit Mixer (Tilted)	1	2	-
10	J.C.B.	1	1	-
11	Excavator / Poclairn	-	1	-
12	Dumper / Trucks 8 Cu.m capacity	1	2	-
13	Dumper / Trucks 4 Cu.m capacity	2	2	-
14	C.C.T.V. Camera	-	1	-
15	Mobile D.G.set	1	1	-
16	Plate Vibrator	-	1	-
17	Crane	-	1	-

The successful bidder will make the arrangements of the required equipment on the day of commencement or with respect to the progress of the work in phases, as per the instructions of site in-charge. The successful bidder and, to that effect he will ensure commitment on an undertaking on Rs.500 stamp paper to be submitted along with the Bid in Packet B. However, this condition in no way shall dilute the respective condition in Registration Rules of BMC.

Note: :-

Bidders shall submit the undertaking for equipment capability and other undertakings as such on a single Rs.500/ stamp paper.

6.9 Technical Personnel

The contractor and/or its managerial staff should have qualification/experience appropriate to the function they fulfill. The minimum standard shall be increased by asking that at least one number or more of the contractor or its managerial staff have acquired qualifications or work experience to the needs of the contract. The minimum standard may also state that the person or persons responsible for managing the works must have a minimum of no's of years experience working on similar nature of projects.

For fixing requirement of Technical Staff as required for this work-

(A) General Guidelines for Fixing Requirement of Technical Staff

Cost of work (Rs in Crore)	Requirement of Technical Staff Qualification	Number	Minimum Experience (year)	Designation
more than 100	i) Graduate Engineer	1	20	Project Manager in major discipline of engineering
	ii) (Major component)			
	iii) Graduate Engineer	2+1	12	Deputy Project Manager in major discipline of engineering
	iv) Graduate Engineer or — Diploma Engineer	4 2	5 10	Project / Site Engineer
	v) Graduate Engineer	1+1	8	Quality Engineer
	vi) Diploma Engineer	1	8	surveyor
	vii) Graduate Engineer	1+1	6	Project Planning / Billing Engineer
more than 50 to 100	i) Graduate Engineer	1	20	Project Manager
	ii) Graduate Engineer	1+1	12	Deputy Project Manager
	iii) Graduate Engineer or — Diploma Engineer	2+1	5 or 10	Project / Site Engineer

	iv) Graduate Engineer	1	8	Quality Engineer
	v) Diploma Engineer	1	8	surveyor
	vi) Graduate Engineer	1+1	6	Project Planning / Billing Engineer
More than 20 to 50	i) Graduate Engineer	1	20	Project Manager
	ii) Graduate Engineer or Diploma Engineer	1 + 1	5 or 10	Project / Site Engineer
	iii) Graduate Engineer	1	8	Quality Engineer
	iv) Diploma Engineer	1	8	surveyor
	v) Graduate Engineer	1	6	Project Planning / Billing Engineer

Note :

- 1 ~~“Cost of work , in the table above , shall mean the aggrement amount of the work.~~
- 2 ~~Rate of recovery in case of non-compliance of the clause be stipulated at following rates~~

Sr. No	Qualification	Experience (years)	Rate of Recovery
1	Project Manager with degree	20	Rs.60000/- p.m.
2	Deputy Project Manager with degree	12	Rs.40000/- p.m.
3	Project/Site Engineer(Degree/Diploma)	5 or 10 respectively	Rs.25000/- p.m.
3	Quality Graduate Engineer	8	Rs.25000/- p.m.
4	Surveyor	8	Rs.15000/- p.m.
5	Project Planning/ Billing Engineer	6	Rs.20000/- p.m.

- 3 ~~Nothing extra need to be added while preparing market rate justified amount of the work if stipulation is made as per above recommended scale of technical staff.~~
- 4 ~~Requirement of technical staff and their experience can be varied depending upon cost and complexity of the work by competent authority i.e. Chief Engineer with recorded reasons.~~
- 5 ~~The failure in providing experienced technical and /professional ability personnel and even ignoring the instruction of the Engineer in charge shall be linked to penalization. Such disobeying attitude of the contractor shall also be reported to Vigilance / Registration and Monitoring department~~

B) General Guidelines for Fixing Requirement of Technical Staff

Requirement of Technical Staff		Minimum Experience (year)	Designation
Qualification	Number		
10 to 20 i) Project Manager with degree in corresponding discipline of Engineering	1	10	Principal Technical Representative
ii) Graduate Engineer	1	5	Technical Representative

	iii) Graduate Engineer or —Diploma Engineer	2 2	2 5	Project / Site Engineer and Project Planning / billing Engr.
5 to 10	i) Graduate Engineer	1	5	Principal Technical Representative
	ii) Graduate Engineer or —Diploma Engineer	2 2	2 5	Project / Site Engineer Engineer
More than 1.5 to 5	i) Graduate Engineer	1	5	Principal Technical Representative
	ii) Graduate Engineer or —Diploma Engineer	1 1	2 5	Project / Site Engineer Billing Engineer
Up to 1.5	i) Graduate Engineer or Diploma Engineer	1 1	2 5	Principal Technical Representative Project / Site Engineer / Billing Engineer

Notes-

1 “Cost of work”, in table above, shall mean the agreement amount of the work.

2. **Rate of recovery in case of non-compliance of the clause be stipulated at following rates :-**

Sr. No	Qualification	Experience (years)	Rate of Recovery
1	Project Manager with degree	10	Rs. 30000/- p.m.
2	Graduate Engineer	5	Rs. 25000/- p.m.
3	Graduate Engineer	2	Rs. 15000/- p.m.
4	Diploma Engineer	2	Rs. 15000/- p.m.

6.10 TIME PERIOD OF THE PROJECT :

Entire project should be completed and delivered within **04 Months** of time from the date of award of contract that **includes / excludes Monsoon**.

The time allowed for carrying out the work as entered in the Tender shall be strictly observed by the Contractor and shall be reckoned from the date on which the **Work Order / Purchase Order** is given to the Contractor. The work shall throughout the stipulated period of the Contract be proceeded with all due diligence as time being deemed to be the essence of the contract on the part of the Contractor. On failing to do so, the Contractor shall pay as compensation an amount which shall be governed as per Clause – 8 (e) of Standard General Conditions of Contract.

The Contractor should complete the work as per phase given below :

¼ of the work in	:	¼ of the time
½ of the work in	:	½ of the time
¾ of the work in	:	¾ of the time
Full of the work in	:	Full of the time

Full work will be completed in **04 Months excluding monsoon**.

The programme for completion of work shall be a part of the Contract Document in the form of Bar Chart / ~~GANTT Chart~~. The Contractor is supposed to carry out the work and keep the progress as per Bar Chart / ~~GANTT Chart~~. The Contractor shall complete the work as per the Schedule given in the Contract and the programme submitted by the Contractor.

6.11 Contract Execution

All required documents for execution of the contract shall be submitted within 30 days from the date of issue of letter of acceptance. If the documents are not submitted within the stipulated time a penalty of Rs 5000/- per day will be applicable to the contractor. All contract documents need to be duly affixed with stamp duty properly signed along with evidence/proof of payment of security/contract deposit/ within 30 days from the date of letter of acceptance received by him

6.12 If the amount of the Contract Deposit to be paid above is not paid within 30 days from the date of issue of Letter of Acceptance, the Tender / Contractor already accepted shall be considered as cancelled and legal steps be taken against the contractor for recovery of the amounts.

6.13 The amount of Security Deposit retained by the BMC shall be released after expiry of period up to which the contractor has agreed to maintain the work in good order is over. In the event of the contractor failing or neglecting to complete the rectification work within the period up to which the contractor has agreed to maintain the work in good order, the amount of security deposit retained by BMC shall be adjusted towards the excess cost incurred by the Department on rectification work.

6.14 Action when whole of security deposit is forfeited:

In any case in which under any Clause of this contract, the contractor shall have rendered himself liable to pay compensation amounting to the whole of this security deposit whether paid in one sum or deducted by instalments or in the case of abandonment of the work owing to serious illness or death of the contractor or any other cause, the Engineer on behalf of the Municipal Commissioner shall have power to adopt any of the following process, as he may deem best suited to the interest of BMC.

- (a) To rescind the contract (for which recession notice in writing to the contractor under the head of Executive Engineer shall be conclusive evidence) and in that case, the security deposit of the contract shall stand forfeited and be absolutely at the disposal of BMC.
- (b) To carry out the work or any part of the work departmentally debiting the contractor with the cost of the work, expenditure incurred on tools and plant, and charges on additional supervisory staff including the cost of work-charged establishment employed for getting the un-executed part of the work completed and crediting him with the value of the work done departmentally in all respects in the same manner and at the same rates as if it had been carried out by the contractor under the terms of his contract. The certificate of the Executive Engineer as to the costs and other allied expenses so incurred and as to the value of the work so done departmentally shall be final and conclusive against the contractor.
- (c) To order that the work of the contractor be measured up and to take such part thereof as shall be un-executed out of his hands, and to give it to another contractor to complete, in which case all expenses incurred on advertisement for fixing a new contracting agency, additional supervisory staff including the cost of work charged establishment and the cost of the work executed by the new contract agency will be

debited to the contractor and the value of the work done or executed through the new contractor shall be credited to the contractor in all respects and in the same manner and at the same rates as if it had been carried out by the contractor under the terms of his contract. The certificate of the Executive Engineer as to all the cost of the work and other expenses incurred as aforesaid for or in getting the un-executed work done by the new contractor and as to the value of the work so done shall be final and conclusive against the contractor.

In case the contract shall be rescinded under Clause (a) above, the contractor shall not be entitled to recover or be paid any sum for any work there for actually performed by him under this contract unless and until the Executive Engineer shall have certified in writing the performance of such work and the amount payable to him in respect thereof and he shall only be entitled to be paid the amount so certified. In the event of either of the courses referred to in Clause (b) or (c) being adopted and the cost of the work executed departmentally or through a new contractor and other allied expenses exceeding the value of such work credited to the contractors amount of excess shall be deducted from any money due to the contractor, by BMC under the contract or otherwise, howsoever, or from his security deposit or the sale proceeds thereof provided, however, the contractor shall have no claim against BMC even if the certified value of the work done departmentally or through a new contractor exceeds the certified cost of such work and allied expenses, provided always that whichever of the three courses mentioned in clauses (a), (b) or (c) is adopted by the Executive Engineer, the contractor shall have no claim to compensation for any loss sustained by him by reason of his having purchase or procured any materials or entered in to any engagements or made any advance on account of or with a view to the execution of the work or the performance of the contract.

6.14. Contract may be rescinded and security deposit forfeited for bribing a public officer or 1 if contractor becomes insolvent.

If the contractor assigns or sublets his contracts or attempt so to do, or become insolvent or commence any proceeding to get himself adjudicated and insolvent or make any composition with his creditors, or attempt so to do or if bribe, gratuity, gift, loan, perquisite, reward or advantage, pecuniary or otherwise, shall either directly or indirectly be given promised or offered by the contractor or any of his servants or agents through any public officer, or person in the employ of BMC / Govt. in any way relating to his office or employment, or if any such officer or person shall become in any way directly or indirectly interested in the contract the Engineer In-charge may thereupon, by notice in writing rescind the contract and the Security Deposit of the Contractor shall thereupon stand forfeited and be absolutely at the disposal of BMC and the same consequences shall ensure as if the contract had been rescinded under above clause J hereof; and in addition the contractor shall not be entitled to recover or be paid for any work therefore actually performed under the contract.

6.15 Submission of Tenders

PACKET – A

The Packet 'A' shall contain scanned certified copies of the following documents -

Scrutiny of this packet will be done strictly with reference to only the scanned copies of Documents uploaded online in packet 'A'

- a) Valid Registration Certificate.
- b) Valid Bank Solvency Certificate of Minimum Solvency amount of **Rs. 3 Lakhs** as governed by Registration Rules in force for respective Class of Contractor for Civil and M&E works.
- c) A document in support of Registration under GST Act 2017.
- d) Certified copies of valid 'PAN' documents and photographs of the individuals, owners, Karta of Hindu undivided Family, firms, private limited companies, registered co-operative societies, partners of partnership firms and at least two Directors, if number of Directors are more than two in case of Private Limited Companies, as the case may be. However, in case of Public Limited companies, Semi Government Undertakings, Government Undertakings, no 'PAN' documents will be insisted.
- e) Latest Partnership Deed in case of Partnership firm duly registered with Chief Accountant (Treasury) of BMC
- f) The Registered power of attorney shall be submitted in the name of person who is submitting the bid.

The bidders shall categorically provide their Email-ID in packet 'A'.

NOTE:

- If the tenderer(s) withdraw tender offer during the tender validity period, his entire E.M.D shall be forfeited.
- If it is found that the tenderer has not submitted required documents in Packet "A" then, the shortfalls will be communicated to the tenderer through e-mail only and compliance required to be made within a time period of **three working days** otherwise they will be treated as non-responsive.

PACKET – B

The Packet 'B' shall contain scanned certified copies of the following documents

- a) The list of similar type of works as stated in para 'A' of Post qualification successfully completed during the last seven years in prescribed proforma, in the role of prime contractor. Information furnished in the prescribed proforma (**Proforma I**) shall be supported by the certificate duly self-attested. Documents stating that it has successfully completed during the last seven years at least one contract of similar works as stated in para 'A' of Post qualification.
- b) Annual financial turnover for **preceding three financial years as certified by Chartered Accountant** preceding the Financial Year in which bids are invited. **Copies of Applicants duly audited balance sheet and profit and loss account for the preceding three financial years preceding the Financial Year in which bids are invited.** (Proforma—II)

- c) ~~Documents stating that, it has access to or has available liquid assets, unencumbered assets, lines of credit and other financial means (independent of any contractual advance payment) sufficient to meet the construction cash flow requirements for the subject contract in the event of stoppage, start-up, or other delay in payment, of the minimum 15% of the cost of the work tendered for, net of the tenderer's commitment of other contracts (Certificate from Bankers / C.A./Financial Institution shall be accepted as a evidence).~~
- d) ~~The bidder shall give undertaking on Rs 500/- stamp paper that it is his/their sole responsibility to arrange the required machineries either owned/on lease or hire basis, at site before start of the work~~

- i) **Regular and Routine works:** The successful bidder shall make the arrangements of the required equipment on the day of commencement or with respect to the progress of the work in phases, as per the instructions of site in charge. ~~The successful bidder and, to that effect he will ensure commitment on an undertaking on Rs.500 stamp paper to be submitted along with the Bid in Packet B. However, this condition in no way shall dilute the respective condition in Registration Rules of BMC.~~
- ii) **New and Original Works:** ~~The bidder should, undertake their own studies and furnish with their bid, a detailed construction planning and methodology supported with assessment study of requirements of equipment/plants & machineries to allow the employer to review their proposal. The bidder shall ensure his commitment to make the arrangements of the required equipment on the day of commencement or with respect to the progress of the work in phases, as per the instructions of site in charge on an undertaking on Rs.500 stamp paper to be submitted along with the Bid in Packet B. However, this condition in no way shall dilute the respective condition in Registration Rules of BMC.~~
- iii) **Special Works:** ~~The concerned Ch.Eng. shall enlist the equipments in the tender document justified for the project and ensure the capacity of the bidder for the same with the approval of concerned AMC.~~

Note: Insistence of availability of equipments/plants at a particular distance from site should not be made in the tender document.

- iv) The list of the "Technical Personnel" with their qualification, working in the tenderers establishment as per proforma IV
- v) ~~Details of works in hand (Proforma VI-A & VI-B) (original), along with copies of work orders & attested copies of percentage of works completed or part thereof.~~
- vi) ~~Statement showing assessed available Bid Capacity.~~
- vii) The undertaking on Rs.500/- stamp paper as per the proforma annexed in Annexure 'B' (Pre-Contract Integrity pact), 'C' (Indemnity bond), 'D' (Best price) and 'F' (irrevocable undertaking) and 'G' conversant to all sites situations and difficulty and also has inspected the site personally and accordingly the bid is submitted. ~~The undertaking shall also include that, he~~

~~will submit license certificate from office of labour commissioner as stated in clause 6.32 after issue of work order and before commencing the work, if the work allotted to him.~~

- viii) Authorisation letter on the letter head of Original Equipment Manufacturer in original and shall be signed in blue ink as per Format (Annexure 'H')
- ix) ~~Pre bid meeting minutes, signed copy of Addendum if any.~~

Note: ~~Bidders shall submit the undertaking for equipment capability and other undertakings as such on a single Rs.500/- stamp paper.~~

- x) The tenderers shall upload work plan as per the following outline:
1. ~~GANTT chart / PERT / CPM chart/Bar chart showing the completion of work within prescribed time period, considering major activities.~~
 2. ~~Organizational set up envisaged by the contractors.~~
 3. ~~Plant & equipment proposed to be deployed for this work.~~
 4. ~~Site Offices and Laboratories proposed to be set up.~~
 5. ~~A note on how the whole work will be carried out (work plan including methodology).~~
 6. ~~Quality management plan.~~
 7. ~~All the activities included in the Scope of Work shall be covered in the work plan.~~

Note:

- i) ~~The Electrical / Mechanical work shall be got carried out by the civil contractors through the contractors registered with BMC. in Electrical Category. Information about the registered contractors shall be obtained from the office of the Ch.E. (M&E)/ E.E. (Monitoring & Registration Cell). Attested scanned copy of the valid registration certificate in Electrical Category shall be uploaded with the tender along with the undertaking from the registered Electrical Contractor stating his willingness to carry out the tender work.~~
- ii) The successful bidder shall submit valid registration certificate under E.S.I.C., Act 1948, if the tenderer has more than 10 employees /persons on his establishment (in case of production by use of energy) and 20 employees/persons on his establishment (in case of production without use of energy) to BMC as and when demanded. In case of less employees/persons mentioned above then the successful bidder has to submit an undertaking to that effect on Rs. 200 stamp paper as per circular u/no. CA/FRD/I/65 of 30.03.2013.
- iii) The successful bidder shall submit valid registration certificate under E.P.F. & M.P., Act 1952, if tenderer has more than 20 employees/persons on his establishment, to BMC as and when demanded. In case if the successful bidder has less employees/persons mentioned above then the successful bidder has to submit an undertaking to that effect on Rs. 200 stamp paper as per circular u/no.

Note:

- **If it is found that the tenderer has not submitted required documents in Packet “B” then, the shortfalls will be communicated to the tenderer through e-mail only and compliance re- quired to be made within a time period of three working days otherwise they will be treated as non-responsive.**

PACKET – C

- a. Online tender filled in either percentage plus or minus (excess or less), or at par. (There is no separate provision to quote % in physical form, this is a part in Header Data of online Tendering). For Packet ‘C’ tenderer(s) will fill data in ‘BOQ’ in Service Line Item via Details and quotes his percentage variation figures. **(If entered ‘0’ it will be treated as ‘at par’.** By default the value is zero only).

Note: In case of rebate/premium of 15 % and above as quoted by the tenderer, the rate analysis of major items shall be submitted by L1 and L2 bidder after demand notification by e-mail to bidders by concerned Dy. H.E. / Dy. Ch. Eng. The format for rate analysis is annexed at Annexure E.

6.16 **BID SECURITY OR EMD**

- The Bidder shall furnish, as part of the Bid, Bid Security / EMD, in the amount specified in the Bid Data Sheet. This bid security shall be in favor of the authority mentioned in the Bid Data Sheet and shall be valid till the validity of the bid.
- The tenderers shall pay the EMD online instead paying the EMD at any of the CFC centres in BMC Ward Offices.
- Any bid not accompanied by an acceptable Bid Security and not secured as indicated in sub-clause mentioned above, shall be rejected by the Employer as non-responsive.
- The Bid Security of the successful Bidder will be discharged when the Bidder has signed the Agreement and furnished the required Security Deposits.
- ~~The Bid Security/ EMD of L-3 bidder shall be refunded immediately after opening of financial bid but, the EMD/ASD submitted by the L-2 bidder will be returned after obtaining Standing Committee Resolution.~~
- The Bid Security may be forfeited:
 - a) if the Bidder withdraws the Bid after bid opening (opening of technical qualification part of the bid during the period of Bid validity;
 - b) in the case of a successful Bidder, if the Bidder fails within the specified time limit to:
 - i. sign the Agreement; and/or

ii. Furnish the required Security Deposits.

In case of non workable rate analysis and misleading information submitted by the bidder, EMD shall be forfeited and bid will be rejected.

Mode of payment of EMD:

A tenderer shall pay entire amount of EMD through payment gateways of GoM on URL <http://mahatenders.gov.in> . The bidder shall upload scan copy of online paid EMD along with the bid submission in packet A.

Any bid not accompanied by an acceptable bid security shall be rejected by the Employer as non responsive.

If non responsive:

If the bidder is found non responsive after scrutiny of packet A/B in such circumstances, **the bidder will be made non responsive and financial packet C of non responsive bidder will not be opened. However there will not be any forfeiture of EMD.**

Shortfalls:

Maximum 5 shortfalls of curable defects shall be allowed and in case, curable defects are not complied by bidder within given time period, the bidder shall be treated as "**Non-Responsive**" & such cases will be informed to Registration and Monitoring Cell. Such non-submission of documents will be considered as 'Intentional Avoidance' & if three or more cases in 12 months are reported, shall be viewed seriously and disciplinary action against the defaulters such as banning / de-registration, etc. shall be taken by the registration cell with due approval of the concerned AMC

Refund of EMD:-

a) Except successful bidder all other unsuccessful bidders 100% EMD paid online will be refunded automatically.

b) The Bid security of successful bidder will be discharged when the bidder has signed the agreement and /or furnish the required security deposits as elaborated in standard bid document.

i) Curable Defect shall mean shortfalls in submission such as:

a. Non-submission of following documents,

i. Valid Registration Certificate

ii. Valid Bank Solvency

iii. GST Registration Certificate

iv. Certified Copies of PAN documents and photographs of individuals, owners, etc

v. Partnership Deed and any other documents

vi. Undertakings as mentioned in the tender document.

vii Wrong calculation of Bid Capacity,

b. ~~In Packet 'A' as well as packet B, 02 nos. Of shortfall in curable defect will be allowed & 2 % EMD will be forfeited for each shortfall thereafter.~~

ii) Non-curable Defect shall mean

- a. In-adequate submission of EMD/ASD amount,**
- b. In-adequacy of technical and financial capacity with respect to Eligibility criteria as stipulated in the tender.**
- c. No proper submission of experience certificates and other documents, etc.**

6.17 BID VALIDITY

- **Bids shall remain valid for a period of not less than one eighty (180) days after the deadline date for bid submission specified in Bid Data Sheet. A bid valid for a shorter period shall be rejected by the Employer as non-responsive.**
- In exceptional circumstances, prior to expiry of the original time limit, the Employer may request that the bidders may extend the period of validity for a specified additional period. The request and the bidders' responses shall be made in writing or by cable. A bidder may refuse the request without forfeiting his Bid Security. A bidder agreeing to the request will not be required or permitted to modify his bid, but will be required to extend the validity of his bid security for a period of the extension.

6.18 DEFECT LIABILITY PERIOD

- The Contractor is expected to carry out the construction work in Workmen like manner so as to meet the requirement and specification for the project. It is expected that the Workmanship & materials will be reasonably fit for the purpose for which they are required.
- Defects or defective work is where standard and quality of workmanship and materials as specified in the contract is deficient. Defect is defined as a failure of the completed work / project to satisfy the express or implied quality or quantity obligations of the ~~construction~~ contract. Defective ~~construction~~ works are as the works which fail short of complying with the express descriptions or requirements of the contract, especially any drawings or specifications with any implied terms and conditions as to its quality, workmanship, durability, aesthetic, performance or design. ~~Defects in construction projects are attributable to various reasons:~~
- ~~Some of the defects are structural defects results in cracks or collapse of faulty defective plumbing, inadequate or faulty drainage system, inadequate or faulty ventilation, cooling or heating systems, inadequate fire systems etc. The defects could be various on accounts of different reasons for variety of the projects.~~
- The Engineering In charge / Project Officer shall issue the practical completion certificate for the project. During the Defect Liability Period which commences on completion of the work, the Engineering In charge shall inform or the contractor is expected to be informed of any defective works by the Employer's representative of the defects and make good at contractor's cost with an intention of giving opportunity to the contractor of making good the defects appeared during that period. It is the contractor's obligation under the contract to rectify the defects that appear during Defect Liability Period and the contractor shall within a reasonable time after receipt of such instructions comply with the same at his own cost. The Engineering In charge / Project Officer shall

issue a certificate to that effect and completion of making good defects shall be deemed for all the purpose of this contract to have taken place on the day named in such defect liability certificate.

- If defective work or workmanship or design have been knowingly covered-up or concealed so as to constitute fraud, commencement of the Defect Liability Period may be delayed. The decided period may be delayed until discover actually occurs on at least the defect could have been discovered with reasonable diligence, whichever is earlier.

The DLP shall be as below:

Dept.	Type of works	DLP
Roads / Bridge	For cement concrete road/ Mastic works-	5 Years
	Asphalt work-	3 Years
	Paver Block-	3 Years
	Structural work-	5 Years
	General works-	5 Years
	General works-	3 Years
BM/SIC/HIC	Structural works-	5 Years
	Waterproofing works-	5 Years
Ward Works-	All ward level works-	2 Years
Other Works-	Pot holes & pre-monsoon bad patch repair work-	1 Year
	HE, WSP, SP, SWD, Garden-	3 year
For other departments-	For laying of CI/DI/MS/MDPE water mains upto and including 300 mm dia and allied works as specified	1 year
	For laying of M.S. water mains above 300 mm dia and allied works as specified	3 year

- Also, in case of defect, the Engineer shall give notice to the Contractor of any Defects before the end of the Defects Liability Period, which begins at. The Defects Liability Period shall be extended for as long as Defects remain to be corrected. Every time notice of Defect/Defects is given, the Contractor shall correct the notified Defect/Defects within the duration of time specified by the Engineer's notice. The Engineer may issue notice to the Contractor to carry out removal of defects or deficiencies, if any, noticed in his inspection, or brought to his notice. The Contractor shall remove the defects and deficiencies within the period specified in the notice and submit to the Engineer a compliance report.

- It is the Completion Stage when the contractor has completed all of the works and fixed all of the defects that were on the list of issue by Engineer-in-charge. When this happens, the engineer must issue a 'Certificate of Completion'. On the issue of 'Certificate of Completion', the 'Defect Liability Period' starts. The contractor also must issue a 'Certificate statement' as an acknowledgment to the engineer not later than 14 days after the 'Certificate of Completion' has been issued. During the 'Defect Liability Period', the contractor has to obey all written instructions from the engineer to carry out repairs and fix any defects which appear in the Permanent Works. If the contractor does not, due to his own faults finish the repair works or fix the defects by the end of 'Defect Liability Period', the 'Defect Liability Period' will continue until all works instructed by engineer is done.
- In case of any lapse in maintenance, the penalties shall be recovered and if necessary the work shall be got done at the risk and cost of the contractor after the prescribed period. The said cost shall be recovered from the Contract Deposit /Retention money or any other deposits, dues with the M.C.G.M. The contractor shall be liable to pay the excess cost if incurred, punitive damages and face penal action in the case of insufficiency of the aforesaid amount.

6.19 SECURITY DEPOSIT AND PERFORMANCE GUARANTEE

A. Security Deposit

The security deposit shall mean and comprise of

- I) Contract Deposit and
 - II) Retention Money.
- I) **Contract Deposit** – The successful tender, here after referred to as the contractor shall pay an amount equal to two (2) percent of the contract sum shall be paid within thirty days from the date of issue of letter of acceptance. **The said contract deposit shall be paid in the form of Demand Draft (D.D.) only**
 - II) **Retention Money** – ~~The contractor shall pay the retention money an amount equal to five (5) percent of the Contract Sum which will be recovered from the contractors every bill i.e. interim / running / final bill.~~ The clause of retention money will not be applicable M&E. Department / works.

B. Additional Security Deposit (Not applicable for Item Rate Tender)

Rebate quoted by contractor	ASD Applicable
Up to 12 % Rebate	No ASD
Rebate above 12.00% on estimated cost	At 2.00% of Estimated cost for each % rebate & part thereof in D.D. only

The ASD is calculated as follows:

Additional security deposit = $(X/100) \times$ office estimated cost,

Where X=percentage rebate quoted above 12%

The bidder shall submit the ASD as applicable in the form of Demand Draft, which is to be submitted during office hours minimum one day before opening of packet 'C' to respective Head Clerk (Expenditure) of the Engineer in-charge of the HE Division in sealed envelope. If A.S.D. is not applicable then the bidders shall submit sealed envelope mentioning on their letter head "ASD is not applicable".

If the bidder fails to submit the sealed envelope as mentioned above at least one day before opening of packet 'C' within office hours then the EMD of the respective bidders will be forfeited and the company with their Directors / Partner and other companies with the said directors / Partner will be further debarred from any tendering process for the period of at least 2 years.

C. Performance Guarantee (Not applicable for item rate tender)

The successful tender, here after referred to as the contractor shall pay in the form of "Performance Guarantee" at different rates for different slabs as stated below:

Offer	PG applicable %
For premium, at par and rebate 0 to 12%	PG = 0.92% x contract sum applicable for rebate of 12%
For rebate of 12.01%	P. G. = {0.92% x contract sum applicable for rebate of 12%} + (X) x contract sum where X = percentage rebate quoted more than 12 %

Note: Contract sum shall mean amount after application of rebate/premium as quoted by the contractor with contingencies only and excluding price variation.

The PG shall be paid in one the following forms.

- I) Cash (In case guarantee amount is less than Rs.10,000/-)
- II) Demand Draft (In case guarantee amount is less than Rs.1,00,000/-)
- III) Government securities
- IV) Fixed Deposit Receipts (FDR) of a Schedule Bank.
- V) An electronically issued irrevocable bank guarantee bond of any Schedule bank or f in the prescribed form given in Annexure.

Performance Guarantee is applicable over and above the clause of Security Deposit.

Performance Guarantee will have to be paid & shall be valid till the defect liability period or finalization of final bill whichever is later.

This deposit will be allowed in the form of I to V as mentioned above and shall be paid within 15 days after receipt of Letter of Acceptance.

~~Note: Following exceptions shall be adopted for 'Demolition Tenders':~~

- ~~● Irrespective of the offer (Rebate/ at par/ premium), ASD shall be differed and only PG of 10% of contract sum be taken from the successful bidder on award of contract only.~~

~~● — BMC departments shall ensure to incorporate specific condition regarding above in bid document and e-tender notice.~~

D. Refund of Security Deposit

I. Refund of Contract Deposit

The Contract Deposit shall be released within 30 days after completion of 3rd year of DLP (in case of 5 years DLP) and after issue of 'Defect Liability Certificate' (in case of 1 or 2 or 3 years DLP) subject to no recoveries are pending against the said work, provided that the Engineer is satisfied that there is no demand outstanding against the Contractor. No claim shall be made against the Balance Contract Deposit after the issue of Defects Liability Certificate.

II. Refund of Retention Money

~~One-half (50%) of the Retention Money shall be released within 30 days of issue of 'Certificate of Completion' with respect to the whole of the Works. In the event the Engineer issues a Taking-over Certificate for a section or part of the Permanent Works, only such proposition thereof as the Engineer determines (having regard to the relative value of such section or part of the Works) shall be considered by the Engineer for payment to the Contractor.~~

~~The balance Retention Money shall be released within 30 days after completion of 3rd year of DLP (in case of 5 years DLP) and after issue of 'Defect Liability Certificate' (in case of 1 or 2 or 3 years DLP) provided that the Engineer is satisfied that there is no demand outstanding against the Contractor. In the event of different Defects Liability Periods have been specified or become applicable to different sections or parts of the Permanent Works, the said moneys will be released within 30 days on expiration of the latest of such Defects Liability Periods.~~

~~Payment of the above mentioned 50% is exclusive of the amounts to be withheld as stated in and that amount shall be paid as per condition stated therein.~~

III. Refund of Additional Security Deposit

One-half (50%) of the additional security deposited (ASD) shall be released after the completion of 50% financial progress of the work.

The balance ASD shall be released within 30 days of issue of "Certificate of completion" with respect to the whole of the work. In the event the Engineer issues a Taking-over Certificate for a section or part of the Permanent Works, only such proposition thereof as the Engineer determines (having regard to the relative value of such section or part of the works) shall be considered by the Engineer for Refund of ASD to the contractor.

IV. Refund of Performance Guarantee

The Deposit on account of performance guarantee shall be released within 30 days of completion of Defects Liability Certificate subject finalization of final bill whichever is later and no recoveries are pending against the said work, provided that the Engineer is satisfied that there is no demand outstanding against the Contractor.

◆ Summary of time of Refund of deposit is tabulated as follows:

a) ~~Time of Refund for works having 5 years DLP~~

~~Deposits refunded after completion~~

~~ASD + 50% of RM~~

~~After 3 yrs of DLP~~

~~CD+50% of RM~~

~~After Completion of DLP~~

~~PG~~

b) Time of Refund for works having 1 or 2 or 3 years DLP

~~Deposits refunded after completion~~

~~ASD + 50% of RM~~

~~After Completion of DLP~~

~~CD +50% of RM+PG~~

***Note:**

- a) ~~It shall be clearly mentioned that the BG shall be applicable for individual work/contract and clubbing of various contracts of the said contractor will not be allowed. In case of obtaining Bank Guarantee, it is necessary to mention that the same shall be valid further 6 months from the completion of defect liability period/warranty period.~~
- b) ~~It shall be the responsibility of the bidder to keep the submitted B.G. "VALID" for the stipulated time period in the tender & in case of its expiry it will attract penalization.~~
- c) ~~Bank Guarantee should be issued by way of General Undertaking and Guarantee issued on behalf of the Contractor by any of the Nationalized or Scheduled banks or branches of foreign banks operating under Reserve Bank of India regulations located in Mumbai upto Virar & Kalyan. List of approved Banks is appended at the end of Instructions to Bidders (ITB). The Bank Guarantee issued by branches of approved Banks beyond Kalyan and Virar can be accepted only if the said Bank Guarantee is countersigned by the Manager of a Regional Branch of the same bank within the Mumbai City Limit categorically endorsing thereon that the said Bank Guarantee is binding on the endorsing Branch of the Bank or the Bank itself within Mumbai Limits and is liable to be enforced against the said Branch of the Bank or the bank itself in case of default by the Contractors furnishing the Bank Guarantee. The Bank Guarantee shall be renewed as and when required and/or directed from time to time until the Contractor has executed and completed the works and remedied any defects therein.~~

E. Legal + Stationary Charges: (As per applicable circular)

Successful tender shall pay the Legal Charges +Stationary charges as per Circular no 26206, dtd 31.08.2023 (effective from 01.09.2023)

Sr. No.	Contract Value in Rs.	Legal + Stationery Charges Rs.
1.	Up to Rs.50,000/-	Nil
2.	From Rs.50,001/- to Rs.1,00,00,000/-	@0.10% of contract cost +18%GST (Min.Rs.1000/-+GST & Max.10000/-+GST)

3.	From Rs.1,00,00,001/- to Rs.10,00,00,000/-	Rs.10000/- for contract cost upto Rs.1,00,00,000/- plus @0.05% for above Rs.1,00,00,000/- +18% GST
4.	Above Rs.10,00,00,001/-	Rs.55000/- for contract cost upto Rs.10,00,00,000/-plus @0.01% for above Rs.10,00,00,000/- +18% GST

The tenderers are requested to note that legal & stationery charges as given in the table above will be recovered from the successful tenderer for supply of requisite prescribed forms for preparing certificate bills in respect of the work.

F. Stamp Duty: (As per applicable circular)

It shall be incumbent on the successful tenderer to pay stamp duty on the contract.

- i. As per the provision made in Article 63, Schedule I of Bombay Stamp Act 1958, stamp duty is payable for “works contract” that is to say, a contract for works and labour or services involving transfer of property in goods (whether as goods or in some other form) in its execution and includes a sub-contract, as under :

(a)	Where the amount or value set forth in such contract does not exceed rupees ten lakh.	Five Hundred rupees stamp duty
(b)	Where it exceeds rupees ten lakhs	Five hundred rupees plus one hundred rupees for every Rs.1,00,000/- or part thereof, above rupees ten lakh subject to the maximum of rupees five lakh stamp duty.
(c)	Bank guarantee : As per article 54 read with 40(b) of stamp duty act, stamp duty of 0.5% will be applicable to all bank guarantee submitted also which are required to be renewed after expiry of time period	0.50%

- ii. The successful bidder shall enter into a contract agreement with BMC Within 30 days from the date of issue of **Work Order** and the same should be adjudicated for payment of Stamp Duty by the successful bidder.
- iii. Further shortfall if any, in amount of stamp duty paid as against prescribed amount for the documents executed in Mumbai City & Mumbai Suburban District be recovered from the concerned work contractors and to deposit the deficit or unpaid Stamp Duty and penalty by two separate Demand Draft or Pay Order in favour of “Superintendent of Stamp, Mumbai” within 15 days from intimation thereof.
- iv. All legal charges and incidental expenses in this respect shall be borne and paid by the successful tenderer.

6.20 IMPORTANT DIRECTIONS

1. All the information uploaded shall be supported by the corroborative documents in absence of which the information uploaded will be considered as baseless and not accepted for qualification criteria. All the documents shall be uploaded with proper pagination. The page No. shall be properly mentioned in the relevant places.

The information shall be uploaded in the sequence as asked for with proper indexing etc. The Bidder shall be fully responsible for the correctness of the information uploaded by him.

2. Applicants / Bidders shall refer portal.mcgm.gov.in\tenders for “The Manual of Bid-Submission for Percentage Rate/Item Rate Tender Document.” The detail guidelines for creation and submission of bid are available in the referred document.

Any queries or request for additional information concerning this TENDER shall be submitted by e-mail to dyhebc@yahoo.com The subject shall clearly bear the following identification / title: "**Queries / Request for Additional Information: TENDER for " Providing new sampling points at Bhandup Complex "**" Any changes in mail ID will be intimated on the portal.

3. In case of **Equal Percentage** of lowest bidders (L1), the allotment of work shall be done by giving 48 hrs (**2 working days**) from the day of opening of packet C **on same BID-Document number for re-quoting** and such development needs to done by IT department in BMC's SRM system. **Till such development is made; 'Sealed Bids' shall be called from the bidders quoting the same rates i.e. L1.**

In case of equal percentage of lowest bidders is obtained even after re-quoting, then the successful bidder will be decided by lottery system by concerned Ch. Eng.

The bidder shall need to submit the additional ASD if applicable within 7 days after receipt of notification issued by concerned Chief Engineer.

Also, the Performance Guarantee shall be paid in 15 days after receipt of Letter of Acceptance

6.21 GENERAL DIRECTIONS TO TENDERERS:

- 1 Firms with common proprietor / partner are connected with one another either financially or as master and servant or with proprietor / partner closely related to each other such as husband, wife, father / mother and minor son / daughter and brother / sister and minor brother / sister, shall not tender separately under different name for the same contract.
- 2 If it is found that firms as described in clause 6.21.1 have tendered separately under different names for the same contract all such tenders shall stand rejected and tender deposit of each such firm /establishments shall be forfeited. In addition, such firms / establishments shall be liable, at the discretion of the Municipal Commissioner, for further penal action including blacklisting.
- 3 If it is found that closely related persons as in clause 6.21.1 have submitted separate tenders under different names of firms, establishment but with common address for such establishment / firms and / or if such establishment firms though they have different address, are managed or governed by the same person / persons jointly or severally such tender shall be liable for action as in clause 6.21.2 including similar action against firms / establishment concerned.

- 4 If after award of contract, it is found that the accepted tenderer violates any of the clauses, 6.21.1, 6.21.2, 6.21.3 the contract shall be liable for cancellation at any time during its currency in addition to penal action against the contractors as well as related firms / establishments.
- 5 Tenderers should note in addition to the official address, they should furnish private residential address, mobile nos., email ids of the partners. Any fault in this respect may justify the rejection of Tender.
- 6 In the event of tender being accepted, full amounts of contract deposit must be paid and contract must be signed by all the partners of the firm and if one or more partners be not available for the purpose, signatory must produce a Power of Attorney must be registered in the office of C.A (Finance) / C.A (Treasury) /C.A (WSSD).
- 7 In the case of a Joint Stock Company, the contract must be sealed with the seal of the company in the presence of and signed by the two Directors or by a person duly authorized to sign the contract for the Company by a power of attorney, such power being sealed and signed as aforesaid. All such power of attorney must be registered in the Municipal Office.

8 Tenderers must distinctly understand:

- a) That they will be strictly required to conform to the conditions of this contract as contained in each of its clauses and that the plea of "custom prevailing" will not on any account be admitted as an excuse on their part for infringement of any of the conditions.
- b) That no alternation or interpolation will be allowed to be made in any of the terms and conditions of this contract or in the Specification of in the Schedule, and that if any such alteration or interpolation be made by a Tenderer, his tender will, at the option of the Municipal Commissioner, either be rejected or to be treated as if no such alteration or interpolation has been made.
- c) That the full contract deposit must be paid within the time specified and the contract must be executed within the stipulated time frame by the successful tenderer.
- d) That a postponement of the payment of the full contract deposit or the execution of the contract will not be permitted by reason of the Corporation having in possession other deposits on account of other tenders or contracts, which deposit may be or become returnable to the tenderers and which they may wish to transfer as a deposit under this contract. Such transfers will not under any circumstances be permitted.

6.22 Tenderers shall note that if the conditions of G.C.C. are in variance with the conditions contained in the tender document the conditions of the tender document shall prevail.

6.23 SITE INSPECTION

Prior to submitting and uploading e-tender for the work the tenderer should visit and examine at the site of works and its surroundings at his own expense and obtain and ascertain for himself, on his own responsibility & risk all information, technical data etc. that may be necessary for preparing his bid and entering into a contract including, inter-alia, the actual conditions regarding the nature and conditions of site, availability of materials, labour, probable sites for Chowky/stores etc. and the extent of lead and lift required for the

execution of the work over the entire duration of the contract, after taking into consideration local conditions, traffic restrictions, obstructions in work, if any allow all such extra expenses that are likely to be incurred due to any such conditions, restrictions, obstructions etc. in the quoted contract price for the work.

They shall obtain further clarification, if any, on any specific issue from the Deputy Hydraulic Engineer (Bhandup Complex) / E.E.(T.C.W.) B.C., the offices of whom are situated at office of Dy.H.E.(Bhandup Complex), Administrative Building, Bhandup Complex Water Treatment Plant, Dargah road, Mulund West, Mumbai- 400082 before submitting the tender. Tenderers/Contractors should note and study the condition related to site constraints and its impact.

6.24 MODIFICATIONS IN TENDER DOCUMENT

If B.M.C. considers it is necessary to carry out any modifications, in the tender documents and extend the closing date of the tender the same shall be made by an addendum. Copy of addendum will be uploaded on B.M.C.'s portal. Each addendum shall be signed by the tenderer(s) and scanned copy of the same should be uploaded in Packet 'B'. The tenderer(s) shall not add or amend the text of any documents contained in tender document.

6.25 TAXES AND DUTIES ON MATERIAL

~~All taxes, duties, cess and charges such as Octroi, Service Tax, Terminal or Sales Tax etc. and other duties on material obtained for the work from any source including the tax applicable as per Maharashtra Sales Tax Act, on the transfer of property in goods involved in the execution of work contracts (re-enacted) Act 1989, Maharashtra State Building & Other Construction Workers Welfare Cess (G.R.No BCA 2009 / C.N/108/ /Labour7-A dated 17.06.10) shall be borne by the tenderer. The tenderer shall not be reimbursed the taxes, duties, cess and charges whether now in force or that may be brought in force. Tenderer should submit necessary octroi receipts to the dept. in respect of material brought by him from supplier outside Mumbai limit.~~

~~Whenever required the tenderer will have to produce a certificate from the Chief Accountant of this Corporation to the effect that the tenderer is not in arrears against his personal account.~~

~~"All charges on account of all Custom Duties, Import Duties, Excise Duties, Business, Income Taxes, Octroi Terminal/VAT/Turnover and other taxes etc. on material, equipment supplies to be used or services to be performed under the contract obtained for the work from any sources as amended up to date shall be borne by the contractor, as per the General Condition of Contract under Taxation Clause and Tender Conditions.~~

~~However, as per the prevailing tax policies of State/Central Government if M.C.G.M. is eligible for getting exemption from excise and other duties or any other taxes payable on any of the material, equipment supplies to be procured or services to be performed for execution of the tender work, then M.C.G.M. will issue work specific Exemption Certificate to the concerned authority for availing the same. Exemption Certificate issued, shall not be misused. If found misused anywhere, then action as deemed fit including blacklisting of the contractor from M.C.G.M. will be taken.~~

~~The tenderer should also note that the execution of work should not be delayed for want~~

~~of exemption certificate. Any taxes and duties paid until issue of exemption certificate will not be reimbursed. The tenderer should note this and quote accordingly."~~

~~Tenderer shall be registered under the Maharashtra Sales Tax on the transfer of property in goods involved in the execution of works contracts (Re-enacted) Act 1989 and should produce documentary evidence of the effect (a copy of registration of certificate from the sales tax department) along with the tender.~~

G.S.T. and other state levies/cess which are not subsumed under GST will be applicable. The tenderer shall quote inclusive of all taxes. It is clearly understood that BMC will not bear any additional liability towards payment of any Taxes and Duties.

Wherever the services to be provided by the tenderer fall under Reverse Charges Mechanism, the price quoted shall be exclusive of GST, but inclusive of Taxes/Duties/Cess other than GST, if any.

Rates accepted by BMC shall hold good till completion of work and no additional individual claim shall be admissible on account of fluctuation in market rates: increase in taxes/any other levies/toll etc. except that payment/ recovery for overall market situation shall be made as per price variation.

- 6.25 a) "As per circular CA / Finance / Proj / City / 17, dated 06.09.2017" Chapter XXI-Miscellaneous, section 171(1) of GST Act-2017 governs the 'Anti Profiting Measure'(AMP). As per the provision of this section, 'Any reduction in rate of tax on any supply of goods or services or the benefit of input tax credit shall be passed on to the recipient by way of commensurate reduction in prices.'

Accordingly , the contractor should pass on the complete benefit accruing to him on account of reduced tax rate or additional input tax credit to BMC.

Further, all the provision of GST Act will be applicable to the tenderer.

6.26 SOLVENCY CERTIFICATE

Tenderer(s) shall upload a scanned copy of latest solvency certificate for required amount from a bank of M.C.G.M approved list attached issued **maximum 12 (twelve) months prior to due date of tender**. Latest solvency certificate shall be submitted in physical format if the tender is awarded to bidder.

6.27 ERRORS AND DISCREPANCIES IN TENDER

If tender contains errors in the Bill of Quantities such as computing mistakes, incorrect transfer etc. the Engineer will inform the tenderer(s) of such errors or discrepancies and rectify the errors or discrepancies and will re-total the amounts of Bill of Quantities. The foregoing procedure may be applied at any time prior to award of contract and the Engineer is not liable for any error or discrepancy which was not discovered during scrutiny of the tender.

- 6.28** In comparing tenders, the corporation shall consider such factors as the efficiency and reliability of instrument and methods proposed, compliance with the specifications, quality and the tenderer's capacity to perform vis-à-vis the time of completion.

6.29 AWARD OF CONTRACT

Notification of award by way of **work order** prior to the tender validity period will be issued

in writing to successful tenderer. The contract will be awarded to the best responsive tenderer(s) offering the lowest evaluated tender in conformity with the tender document. Corporation reserves right to accept/reject any or all tenders and to annul the tendering process at any time prior to award of contract. Prior to the expiry of the Tender validity, the Corporation will notify the successful tenderer(s) by a letter that his tender has been accepted, if required. This letter herein after and in condition of contract called “The Letter of the Acceptance”. Notification of Award will constitute the information of contract.

SECTION 7

SCOPE OF WORK

SCOPE OF WORK

The water treatment plant of capacity 1910 MLD at Bhandup Complex was commissioned in the year 1981. Up to Jan.2023, raw water is coming at inlet points(old) of pre-treater through 2750mm dia. pipeline and 5000mm dia. Tunnel. Now from 1 Feb.2023, raw water is also coming from Gundwali tunnel through 3000mm dia pipe at other inlet points(new) of Pre-treater.

Raw water from old inlet point was travel through 4 stream A,B,C,D separately without mixing with each other, Now after new inlet points, raw water from old inlet point mixes with raw water from new inlet point in stream A & B and C& D in both ends before Pre-treatment. Due to uneven mixing of raw water, dose of PAC can not be determined correctly which further affects the turbidity of final treated water. Hence to determine correct PAC dose, new 4 new raw water sampling points are proposed for stream A,B,C & D at Pre-treater.

Also to check the quality of final treated water stored in old MBR & new MBR, two sampling points from old MBR and one sampling point from new MBR is proposed. Now from all this new sampling points, water is to be bring at Bhandup Complex laboratory through pipeline for testing purpose.

SECTION 8
BILL OF QUANTITIES

BRIHANMUMBAI MUNICIPAL CORPORATION

Schedule of Quantities and Rates

Sub. : Providing new sampling points at Bhandup Complex

Sr. No.	USOR 2023 Item No.	Description of item	Unit	Qty.	Rate per unit Rs. (Excluding GST)	Amount in Rs. (Excluding GST)
1	R3-ME-6-2	SUBMERSIBLE PUMPSETS (OPEN WELL) (SP-ME-TS-15): Providing, installing and giving test of submersible pumpset directly coupled to submersible electric motor complete with suction strainer, antithrust streamlined non return valve, minimum 4 m submersible type copper conductor cable and 2 pairs of suitable size 10 mm thick erection clamps, 4 m lifting chain and 1 submersible cable connection kit shall be provided with each pump set.				
1.1	R3-ME-6-2-e	Submersible Pump set of: 1 H.P. single/ three phase electric motor Discharge: 90 lpm at 22 m head to 45 lpm at 52 m head Pump body: SS, Impeller:SS 304 , Shaft SS410 Pump delivery diameter 32 mm	NOS.	8	15963.00	127704.00
2	R3-ME-1-14	Distribution board with metal door of various sizes on wall/ Column / floor mounting, with required hardware & fasteners. For MCCB incomers, ON/OFF & TRIP indication lamps shall be provided. All MCBs shall be rated for 10kA, 'C' curve type. All the DBs are readymade DBs				

		inclusive of MCCB, MCB, terminal connectors, earth bus, neutral bus, undrilled gland plate and earth terminals (2Noss.) Cost of DBs include rates of DB, MCB, MCCB & other accessories				
2.1	R3-ME-1-14-e	IP 42 Wall/column Mounted distribution board with one Nos of 16A DP MCB as incomer and 4 Noss 6/10A SP MCB as outgoing (8way SPN DB)	NOS.	2	4488.00	8976.00
3	R3-ME-2-12	Cable end terminations for LV, XLPE/PVC insulated, PVC sheathed, armoured/unarmoured cables including supply and fixing of Double compression cable glands, stripping of cable insulation, supply and fixing of tinned plated copper lugs for copper cables for all phases and crimping the same to the conductor for the following cables. Miscellaneous items like cable lugs, G.I nut - bolts and G.I washers , consumables and other hardware materials as required to make the installation complete, are in the scope. All G.I Nut, bolt and washers shall be HDGI with 80 micron. One set of termination includes gland, lugs for cable core & accessories				
3.1	R3-ME-2-12-g	Cable End Termination For Copper Cables – 3C x 2.5 Sq.mm	set	44	118.00	5192.00
4	R3-ME-2-3	1.1 kV grade stranded Cu conductor, XLPE insulated, extruded PVC inner and FRLS outer sheathed, galvanised steel round or strip armoured cables (SP-ME-TS- 6				

4.1	R3-ME-2-3-f	st 1 category Cu armoured cables FRLS outer sheathed- 3C x 2.5	Mtrs	200	142.00	28400.00
5	R3-ME-1-21	Sheet Moulding compound (SMC) Junction Box, for Outdoor				
5.1	R3-ME-1-21-a	SMCJB - 1414, Hinged cover, Size 170 x 170 x 105mm	Nos.	8	1281.00	10248.00
6	R3-ME-1-22	Starter for Motors : (Complete with Interconnections & Wiring) (SP-ME-TS- 1): Following rating starters. Enclosure for starter shall be Corrosion resistant powder coated CRCA enclosure with IP54 protection class shall be suitable for chemical factories, polluted industrial and dusty agricultural environment. Starters shall be provided with terminal block with proper terminal marking for ease of wiring. Terminal block can accommodate both aluminum & copper cables. Starter shall be provided with ON / OFF Indication lamps and Start / Stop Push buttons. Components for motor starter shall have type 2 co-ordination compliance and built in single phase protection. Colour shade shall be RAL 7032 smoke gray as per IS 5.				
6.1	R3-ME-1-22-a	Single Phase DOL starter, fractional H.P To 1 H.P	Nos.	8	1489.00	11912.00
7	R3-ME-1-31	SUPPLY & INSTALLATION OF ANGLE IRON FRAME WORK				
7.1	R3-ME-1-31-c	50 x 50 x 6 mm of M.S.angle.	Mts.	80	639.00	51120.00

7.2	R3-ME-1-31-f	Flat bars 50 mm x 6 mm thick.	Mrs.	20	367.00	7340.00
8	R3-ME-2-13	Readymade 2500mm standard length, prefabricated, perforated cable tray from MS sheet and then hot dip galvanised, of following sizes and associated accessories such as coupler plates, tees, elbow etc. Galvanisation thickness shall be minimum 86 Micron.				
8.1	R3-ME-2-13-b	G.I. Cable tray with all other accessories 100 x 25mm (W x H) -(16 SWG - 1.6mm) without cover	Mtrs	100	349.00	34900.00
9	R3-ME-2-15	Readymade 2500mm standard length, prefabricated, GI trunking from MS sheet and then hot dip galvanised, of following sizes and associated accessories such as coupler plates, tees, elbow etc. 50 mm side flanges shall be provided. Galvanisation thickness shall be minimum 86 Micron. cost of trunking shall be included junction box of suitable size, and all other accessories required to complete the work.				
9.1	R3-ME-2-15-d	G.I. Trunking / Duct / Raceway & all other accessories – 150 x 40mm (W x H) - (14 SWG - 2mm) with cover without partition	Mtrs.	30	597.00	17910.00
10	R3-CS-PS-86	Providing and fixing Chlorinated Polyvinyl Chloride (CPVC) pipes, having thermal stability for hot & cold water supply, including all CPVC plain & brass threaded fittings, i/c fixing the pipe with clamps at 1.00 m spacing. This includes jointing of pipes & fittings with one step				

		CPVC solvent cement and the cost of cutting chases and making good the same including testing of joints complete as per direction of Engineer in Charge				
10.1	R3-CS-PS-86-c	25 mm nominal outer dia Pipes	Rmt	2100	484.00	1016400.00
11	R3-CS-PS-87	Providing and fixing Chlorinated Polyvinyl Chloride (CPVC) pipes, having thermal stability for hot & cold water supply including all CPVC plain & brass threaded fittings This includes jointing of pipes & fittings with one step CPVC solvent cement ,trenching ,refilling & testing of joints complete as per direction of Engineer in Charge.				
11.1	R3-CS-PS-87-c	25 mm nominal outer dia Pipes	Rmt	2300	270.00	621000.00
12	R3-CS-PS-225-a	Providing, fixing and testing heavy quality gun metal or brass ball valve with screwed ends 20kgm class on GI or copper pipe lines(Leader/ZOLOTO make) 15 mm (1/2") dia.	Nos.	4	633.00	2532.00
13	R3-CS-PS-225-c	Providing, fixing and testing heavy quality gun metal or brass ball valve with screwed ends 20kgm class on GI or copper pipe lines (Leader/ZOLOTO make) 25 mm (1") dia.	Nos.	10	1088.00	10880.00
14	R3-CS-EW-17	Excavation by chiseling by manual operations, pneumatic breaker, hammer, drilling, compressor breaker, jack hammer etc. over areas for basements, roads, land/plot developement etc. in hard rock, reinforced concrete, Bituminous macadam for all depths/lifts including manual dewatering, filling the selected excavated earth at the locations as	Cum	3	1232.00	3696.00

		directed, in layers not more than 200mm thickness, watering, consolidating, compacting to achieve not less than 97% Modified Proctor density conforming to relevant IS, stacking the selected material in measurable heaps for future use within owners space or disposing within an initial lead of 150m as directed, loading, unloading, leveling excluding shoring, strutting etc. complete as by Engineer-inCharge. Note: 1) The rate includes the handling/supporting the existing utilities such as cables, drains, pipes, water mains etc. 2) It also includes the royalty and other taxes if any.				
15	R3-HE-7-1	Supplying G.I C Class Pipes having embossed ISI mark on it and Conforming to IS: 1293 (Latest Edition) of the following diameter excluding all local and central taxes, octroi, inspection charges, transportation to stores etc complete in all respect as directed by Engineer in Charge. Note : Only GI pipe brands from the MCGM approved vendor list shall be used, all pipe and pipe fittings shall be C class (heavy grade) having ISI marking.				
15.1	R3-HE-7-1-h	80mm	Rmt	50	606.00	30300.00
16	R3-RW-5-02	Supplying & spreading of one or more layers of compacted crushed coarse agg. with alternate application of bituminous binder & key aggregate with the requirements of MORTH, Rolling with 10/12 mt roller using VG-30 grade bitumen (1% Antistripping agent) to serve as base course and	SQM	8	475.00	3800.00

		inconformity with the line, level and cross sections shown on the drawings or as directed by the Egg., thickness of individual course shall not exceed 50 mm. (As per prevailing MCGM specification for Roadwork Clause No. 352) SQM 475.00 R3-RW-5-03 P/L premix hot mi				
					Total:	1992310.00

SECTION 9
GENERAL CONDITIONS OF
CONTRACT

General Conditions of Contract

A. General

1. Definitions

1.1 Terms which are defined in the Contract Data are not also defined in the Conditions of Contract but keep their defined meanings. Capital initials are used to identify defined terms.

The “Contract” shall mean the tender and acceptance thereof and the formal agreement if any, executed between the Contractor, Commissioner and the Corporation together with the documents referred to therein including these conditions and appendices and any special conditions, the specifications, designs, drawings, price schedules, bills of quantities and schedule of rates. All these documents taken together shall be deemed to form one Contract and shall be complementary to one another.

The Contract Data defines the documents and other information which comprise the Contract.

The “Contractor” shall mean the individual or firm or company whether incorporated or not, whose tender has been accepted by the employer and the legal successor of the individual or firm or company, but not (except with the consent of the Employer) any assignee of such person.

The Bidder is a person or corporate body who has desired to submit Bid to carry out the Works, including routine maintenance till the tender process is concluded.

The Contractor's Bid is the completed bidding document submitted by the Contractor to the Employer.

The “Contract Sum” means the sum named in the letter of acceptance including Physical contingencies subject to such addition thereto or deduction there-from as may be made under the provisions hereinafter contained.

Note : The contract sum shall include the following –

- In the case of percentage rate contracts the estimated value of works as mentioned in the tender adjusted by the Contractor’s percentage.
- In the case of item rate contracts, the cost of the work arrived at after finalisation of the quantities shown in schedule of items / quantities by the item rates quoted by the tenderers for various items and summation of the extended cost of each item.
- In case of lumpsum contract, the sum for which tender is accepted.
- Special discount / rebate / trade discount offered by the tenderer if any and accepted by the Corporation.
- Additions or deletions that are accepted after opening of the tenders.

The “Contract Cost” means the Contract Sum plus Price Variation. This cost shall be included in the letter of acceptance.

A Defect is any part of the Works not completed in accordance with the Contract.

The Defects Liability Certificate is the certificate issued by the Engineer, after the Defect Liability Period has ended and upon correction of Defects by the Contractor.

Drawings means all the drawings, calculations and technical information of a like nature provided by the Engineer to the Contractor under the Contract and all drawings, calculations, samples, patterns, models, operation & maintenance manual and other technical information of like nature submitted by the Contractor and approved by the Engineer.

The Authority shall mean BRIHANMUMBAI MUNICIPAL CORPORATION (BMC)

The “Employer” shall mean the Municipal Corporation for Greater Mumbai / Municipal Commissioner for Greater Mumbai, for the time being holding the said office and also his successors and shall also include all “Additional Municipal Commissioners, Director (Engineering Services & Projects)” and the Deputy Municipal Commissioner, to whom the powers of Municipal Commissioner, have been deputed under Section 56 and 56B of the Mumbai Municipal Corporation Act.

The Engineer in-charge shall mean the Executive Engineer in executive charge of the works and shall include the superior officers of the Engineering department i.e. Dy.Ch.Eng / Ch.Eng. and shall mean and include all the successors in BMC

The Engineer's Representative shall mean the Assistant Engineer, Sub. Engineer / Jr. Engineer in direct charge of the works and shall include Sub Eng./ Jr. Eng of Civil section/ Mechanical section/ Electrical section appointed by BMC.

The “Engineer” shall mean the City Engineer / the Hydraulic Engineer / the Chief Engineer / the Special Engineer, appointed for the time being or any other officer or officers of the Municipal Corporation who may be authorized by the commissioner to carry out the functions of the City Engineer / the Hydraulic Engineer / the Chief Engineer / the Special Engineer or any other competent person appointed by the employer and notified in writing to the Contractor to act in replacement of the Engineer from time to time.

Contractor's Equipment means all appliances and things of whatsoever nature required for the execution and completions of the Works and the remedying of any defects therein, but does not include plant material or other things intended to form or forming part of the Permanent Works.

The Initial Contract Price is the Contract Price listed in the Employer's Letter of Acceptance.

The Intended Completion Date is the date on which it is intended that the Contractor shall complete the construction works. The Intended Completion Date is specified in the Contract Data. The Intended Completion Date may be revised only by the Engineer by issuing an extension of time.

Materials are all supplies, including consumables, used by the Contractor for incorporation in the Works and works of routine maintenance.

Plant is any integral part of the Works that shall have a mechanical, electrical, electronic, chemical, or biological function.

Routine Maintenance is the maintenance of activities of the completed structure for five years as specified in the Contract Data..

The “Site” shall mean the land and other places including water bodies more specifically mentioned in the special conditions of the tender, on, under in or through which the permanent works or temporary works are to be executed and any other lands and places provided by the Municipal Corporation for working space or any other purpose as may be specifically designated in the contract as forming part of the site.

Site Investigation Reports are those that were included in the bidding documents & are reports about the surface and subsurface conditions at the Site.

“Specification” shall mean the specification referred to in the tender and any modification thereof or addition or deduction thereto as may from time to time be furnished or approved in writing by the Engineer.

The Start Date/Commencement Date is given in the Contract Data. It is the date when the Contractor shall commence execution of the Works. It does not necessarily coincide with any of the Site Possession Dates.

A Nominated Sub-Contractor is a person or corporate body who has a Contract with the Contractor to carry out a part of the construction work and/or routine maintenance in the Contract, which includes work on the Site.

Temporary Works are works designed, constructed, installed, and removed by the Contractor that are needed for construction or installation of the Works.

Variation means a change to the:-

- i) Specification and /or Drawings (if any) which is instructed by the Employer.
- ii) Scope in the Contract which is instructed by the Employer.
- iii) Price in the Contract which is instructed by the Employer.

The Works, as defined in the Contract Data, are what the Contract requires the Contractor to construct, install, maintain, and turn over to the Employer. Routine maintenance is defined separately.

Jurisdiction: In case of any claim, dispute or difference arising in respect of a contract, the cause of action thereof shall be deemed to have arisen in Mumbai and all legal proceedings in respect of any claim, dispute or difference shall be instituted in a competent court in the City of Mumbai only.

2. Interpretation

- 2.1 In interpreting these Conditions of Contract, singular also means plural, male also means female or neuter, and the other way around. Headings have no significance. Words have their normal meaning under the language of the Contract unless specifically defined. The Engineer will provide instructions clarifying queries about these Conditions of Contract.
- 2.2 If sectional completion is specified in the Contract Data, references in the Conditions of Contract to the Works, the Completion Date, and the Intended Completion Date apply to any Section of the Works (other than references to the Completion Date and Intended Completion Date for the whole of the Works).
- 2.3 The documents forming the Contract shall be interpreted in the following documents: (1) Agreement, (2) Letter of Acceptance, (3) Notice to Proceed with the Work , (4) Contractor's Bid,(5) Contract Data, (6) Special Conditions of Contract Part (7) General Conditions of Contract Part I, (8) Specifications, (9) Drawings, (10) Bill of Quantities, and (11) Any other document listed in the Contract Data.

3. Engineer's Decisions

- 3.1 Except where otherwise specifically stated, the Engineer will decide contractual matters between the Employer and the Contractor in the role representing the Employer. However, if the Engineer is required under the rules and regulations and orders of the Employer to obtain prior approval of some other authorities for specific actions, he will so obtain the approval, before communicating his decision to the Contractor.
- 3.2 Except as expressly stated in the Contract, the Engineer shall not have any authority to relieve the Contractor of any of his obligations under the contract.

4. Delegation

- 4.1 The Engineer, with the approval of the Employer, may delegate any of his duties and responsibilities to other person(s), except to the Adjudicator, after notifying the Contractor, and may cancel any delegation after notifying the Contractor.

5. Communications

All certificates, notices or instructions to be given to the Contractor by Employer/ Engineer shall be sent on the address or contact details given by the Contractor of Bid. The address and contact details for communication with the Employer / Engineer shall be as per the details given in Contract Data. Communications between parties that are referred to in the conditions shall be in writing. The Notice sent by facsimile (fax) or other electronic means shall be effective on confirmation of the transmission. The Notice sent by Registered post or Speed post shall be effective on delivery or at the expiry of the normal delivery period as undertaken by the postal service.

6. Subcontracting

- 6.1 Unless specifically mentioned in the contract subletting will not be allowed. Subletting,

where otherwise provided by the contract shall not be more than 25% of the contract price.

- 6.2 The Contractor shall not be required to obtain any consent from the Employer for:
- a. the sub-contracting of any part of the Works for which the Subcontractor is named in the Contract;
 - b. the provision for labour, or labour component.
 - c. the purchase of Materials which are in accordance with the standards specified in the Contract.
- 6.3 Beyond what has been stated in clauses 6.1 and 6.2, if the Contractor proposes sub contracting any part of the work during execution of the Works, because of some unforeseen circumstances to enable him to complete the Works as per terms of the Contract, the Employer will consider the following before according approval:
- a. The Contractor shall not sub-contract the whole of the Works.
 - b. The permitted subletting of work by the Contractor shall not establish any contractual relation- ship between the sub-contractor and the BMC and shall not relieve the Contractor of any re- sponsibility under the Contract.
- 6.4 The Engineer should satisfy himself before recommending to the Employer whether
- a. the circumstances warrant such sub-contracting; and
 - b. the sub-Contractor so proposed for the Work possesses the experience, qualifications & equipment necessary for the job proposed to be entrusted to him.

7. Other Contractors

- 7.1 The Contractor shall cooperate and share the Site with other Contractors, public authorities, utilities, and the Employer between the dates given in the Schedule of Other Contractors, as referred to in the Contract Data. The Contractor shall also provide facilities and services for them as described in the Schedule. The Employer may modify the Schedule of Other Contractors, and shall notify the Contractor of any such modification.
- 7.2 The Contractor should take up the works in convenient reaches as decided by the Engineer to ensure there is least hindrance to the smooth flow and safety of traffic including movement of vehicles & equipment of other Contractors till the completion of the Works.

8. Personnel

- 8.1 The Contractor shall employ for the construction work and routine maintenance the key personnel including technical personnel named in the Contract Data or other personnel approved by the Engineer. The Engineer will approve any proposed replacement of technical personnel only if their relevant qualifications and abilities are substantially equal to those of the personnel stated in the Contract Data.
- 8.2 The Contractor's personnel shall appropriately be qualified, skilled and experienced in their respective trades or occupations. The Engineer shall have authority to remove, or cause to

be removed, any person employed on the site or works, who carries out duties incompetently or negligently and persists in any conduct which is prejudicial to safety, health or the protection of the environment.

8.3 If the Engineer asks the Contractor to remove a person who is a member of the Contractor's staff or work force, stating the reasons, the Contractor shall ensure that the person leaves the Site within seven days and has no further connection with the Works in the Contract.

8.4 The Contractor shall not employ any retired Gazetted officer who has worked in the Engineering Department of the BMC / State Government and has either not completed two years after the date of retirement or has not obtained BMC / State Government's permission to employment with the Contractor.

9. Employer's and Contractor's Risks

9.1 The Employer carries the risks which this Contract states are Employer's risks, and the Contractor carries the risks which this Contract states are Contractor's risks.

10. Employer's Risks

10.1 The Employer is responsible for the excepted risks which are (a) in so far as they directly affect the execution of the Works in the Employer's country, the risks of war, invasion, act of foreign enemies, rebellion, revolution, insurrection or military or usurped power, civil war, riot, commotion or disorder (unless restricted to the Contractor's employees) and contamination from any nuclear fuel or nuclear waste or radioactive toxic explosive, or (b) a cause due solely to the design of the Works, other than the Contractor's design.

11. Contractor's Risks

11.1 All risks of loss of or damage to physical property and of personal injury and death which arise during and in consequence of the performance of the Contract other than the excepted risks, referred to in clause 11.1, are the responsibility of the Contractor

12. Insurance

12.1 The Contractor at his cost shall provide, in the joint names of the Employer and the Contractor, insurance cover from the Start Date to the end of Defects Liability Period, in the amounts and deductibles stated in the Contract Data for the following events which are due to the Contractor's risks:

- a) Loss of or damage to the Works, Plant and Materials;
- b) Loss of or damage to Equipment;
- c) Loss of or damage to property (other than the Works, Plant, Materials, and Equipment) in connection with the Contract; and
- d) Personal injury or death.

12.2 Insurance policies and certificates for insurance shall be delivered by the Contractor to the Engineer for the Engineer's approval before the Start Date. All such insurance shall provide for compensation to be payable in the types and proportions of currencies required to rectify

the loss or damage incurred.

12.3 Alterations to the terms of insurance shall not be made without the approval of the Engineer.

12.4 Both parties shall comply with any conditions of the insurance policies .

12.5 If the Contractor does not provide any of the policies and certificates required, the Employer may affect the insurance which the Contractor should have provided and recover the premiums the Employer has paid, from payments otherwise due to the Contractor or if no payment is due, the payment of premiums shall be debt due.

13. Site Investigation Reports

13.1 The Contractor, in preparing the Bid, may rely, at his own risk, on any Site Investigation Reports referred to in the Contract Data, supplemented by any other information available to him, before submitting the bid.

14. Queries about the Contract Data

14.1 The Engineer will clarify queries on the Contract Data.

15. Contractor to Construct the Works & Undertake Maintenance (if specified in the tender)

15.1 The Contractor shall construct, and install and maintain the Works in accordance with the Specifications and Drawings and as per instructions of the Engineer.

15.2 The Contractor shall construct the works with intermediate technology, i.e., by manual means with medium input of machinery required to ensure the quality of works as per specifications. The Contractor shall deploy the equipment & machinery as required in the contract.

15.3 The Contractor shall take all reasonable steps to protect the environment on and off the Site and to avoid damage or nuisance to persons or to property of the public or others resulting from pollution, noise or other causes arising as a consequence of his methods of operation.

During continuance of the contract, the Contractor and his sub-contractors shall abide at all times by all existing enactments on environmental protection and rules made there under, regulations, notifications and byelaws of the State or Central Government, or local authorities and any other law, bye-law, regulations that may be passed or notification that may be issued in future by the State or Central Government or the local authority. Salient features of some of the major laws that are applicable are given below:

- The Water (Prevention and Control of Pollution) Act, 1974, this provides for the prevention and control of water pollution and the maintaining and restoring of wholesomeness of water. 'Pollution' means such contamination of water or such alteration of the physical, chemical or biological properties of water or such discharge of any sewage or trade effluent or of any other liquid, gaseous or solid substance into water (whether directly or indirectly) as may, or is likely to, create a nuisance or render such water harmful or injurious to public health or safety, or to domestic, commercial, industrial, agricultural or other legitimate uses, or to the life and health

of animals or plants or of aquatic organisms.

- The Air (Prevention and Control of Pollution) Act, 1981, this provides for prevention, control and abatement of air pollution. 'Air Pollution' means the presence in the atmosphere of any 'air pollutant', which means any solid, liquid or gaseous substance (including noise) present in the atmosphere in such concentration as may be or tend to be injurious to human beings or other living creatures or plants or property or environment.
- The Environment (Protection) Act, 1986, this provides for the protection and improvement of environment and for matters connected therewith, and the prevention of hazards to human beings, other living creatures, plants and property. 'Environment' includes water, air and land and the inter-relationship which exists among and between water, air and land, and human beings, other living creatures, plants, micro-organism and property.
- The Public Liability Insurance Act, 1991, This provides for public liability insurance for the purpose of providing immediate relief to the persons affected by accident occurring while handling hazardous substances and for matters connected herewith or incidental thereto. Hazardous substance means any substance or preparation which is defined as hazardous substance under the Environment (Protection) Act 1986, and exceeding such quantity as may be specified by notification by the Central Government.

16. The Works and Routine Maintenance to be completed by the Intended Completion Date

16.1 The Contractor may commence execution of the works on the Start Date and shall carry out the Works and Routine Maintenance, if specified in the tender, in accordance with the Programme submitted by the Contractor, as updated with the approval of the Engineer, and complete them by the Intended Completion Date.

17. Approval by the Engineer

17.1 The Contractor shall submit Specifications and Drawings showing the proposed Temporary Works to the Engineer, who is to approve them if they comply with the Specifications and Drawings.

17.2 The Contractor shall be responsible for design and safety of Temporary Works.

17.3 The Engineer's approval shall not alter the Contractor's responsibility for design and safety of the Temporary Works.

17.4 The Contractor shall obtain approval of third parties to the design of the Temporary Works, where required.

17.5 All Drawings prepared by the Contractor for the execution of the temporary or permanent Works, are subject to prior approval by the Engineer before their use.

18. Safety

18.1 The Contractor shall be responsible for the safety of all activities on the Site. He shall comply with all applicable safety requirements and take care of safety of all persons

entitled to be on the site and the works. He shall use reasonable efforts to keep the site and the works, both during construction and maintenance, clear of unnecessary obstruction so as to avoid danger to the persons and the users.

- Workers employed on mixing asphaltic materials, cement and lime mortars shall be provided with protective footwear and protective goggles.
- Stone breaker shall be provided with protective goggles and protective clothing and seated at sufficiently safe intervals.
- The area should be barricaded or cordoned off by suitable means to avoid mishaps of any kind. Power warning signs should be displayed for the safety of the public whenever cleaning works are undertaken during night or day.
- The workers engaged for cleaning the manholes/sewers should be properly trained before allowing working in the manhole.

18.2 Safety Programs:-

- i. Have adequate safety supervision in place to ensure that safety programs set up by the firms/agencies are in compliance with prevalent laws and regulations.
- ii. Review safety programs developed by each of the trade firms, prepare and submit a comprehensive safety program.
- iii Monitor day to day implementation of safety procedures.

18.3 First Aid Facilities: -

- i. At every work place there shall be provided and maintained, so as to be easily accessible during working hours, first-aid boxes at the rate of not less than one box for 150 contract labour or part thereof ordinarily employed.
- ii. The first-aid box shall be distinctly marked with a red cross on white back ground.
- iii. Adequate arrangements shall be made for immediate recoupment of the equipment when necessary.
- iv. Nothing except the prescribed contents shall be kept in the First-aid box.
- v. The first-aid box shall be kept in charge of a responsible person who shall always be readily available during the working hours of the work place.
- vi. A person in charge of the First-aid box shall be a person trained in First-aid treatment, in the work places where the number of contract labour employed is 150 or more.

19. Discoveries

- 19.1 Anything of historical or other interest or of significant value unexpectedly discovered on the Site shall be the property of the Employer. The Contractor shall notify the Engineer of such discoveries and carry out the Engineer's instructions for dealing with them.

20. Possession of the Site

- 20.1 The Employer shall handover complete or part possession of the site to the Contractor 7 days in advance of construction programme. At the start of the work, the Employer shall

handover the possession of at-least 75% of the site free of all encumbrances, the remaining 25 % of the possession as per contractor's construction programme.

21. Access to the Site

21.1 The Contractor shall allow access to the Site and to any place where work in connection with the Contract is being carried out, or is intended to be carried out to the Engineer and any person / persons / agency authorized by: a. The Engineer, b. The Employer or authorized by the Employer.

22. Instructions

22.1 The Contractor shall carry out all instructions of the Engineer, which comply with the applicable laws where the Site is located.

22.2 The Contractor shall permit the appointed and/or authorized persons to inspect the Site and/or accounts and records of the Contractor and its subcontractors relating to the performance of the Contract, and to have such accounts and records audited by auditors appointed, if so required. The Contractor's attention is invited to Clause of 'Fraud and Corruption', which provides, inter alia, that acts intended to materially impede the exercise of the inspection and audit rights provided for under the Clause & constitute a obstructive practice subject to contract termination.

22.3 Engineer to have power to issue further drawings or instructions:

The Engineer shall have the power and authority from time to time and at all times to make and issue such further drawings and to give such further instructions and directions as may appear to him necessary or proper for the guidance of the contractor and the good and sufficient execution of the works according to terms of the specifications and Contractor shall receive, execute, obey and be bound by the same, according to the true intent and meaning thereof, as fully and effectually as though the same had accompanied or had been mentioned or referred to in the specification, and the Engineer may also alter or vary the levels or position of nature of works contemplated by the specifications, or may order any of the works contemplated thereby to be omitted, with or without the substitution of any other works in lieu thereof, or may order any work or any portion of work executed or partially executed, to be removed, changed or altered, added if needful, may order that other works shall be substituted instead thereof and difference of expense occasioned by any such diminution or alteration so ordered and directed shall be added to or deducted from the amount of this Contract, as provided under condition no.10 (a) hereinafter.

No work which radically changes the original nature of the Contract shall be ordered by the Engineer and in the event of any deviation being ordered which in the opinion of the Contractor changes the original nature of Contract he shall nevertheless carry it out and disagreement as to the nature of the work and the rate to be paid therefore shall be resolved in accordance with condition no.13d.

The time for completion of the Works, shall be in even of any deviations resulting in additional cost over the contract price being ordered, be extended or reduced reasonably by the Engineer. The Engineer's decision in this case shall be final.

B. Time Control

23. Programme

- 23.1 Within the time stated in the Contract Data, the Contractor shall submit to the Engineer for approval a Programme, including Environment Management Plan showing the general methods, arrangements, order, and timing for all the activities in the Works, along with monthly cash flow forecasts for the construction of works.
- After the completion of the construction works, the programme for the Routine Maintenance Work, showing the general methods, arrangements, order and timing for all the activities involved in the Routine Maintenance will also be submitted by the Contractor to the Engineer for approval if specified in the tenders.
- The programme for Routine Maintenance will be submitted in each year for the period of Maintenance.
- 23.2 The Contractor shall submit the list of equipment and machinery being brought to site, the list of key personnel being deployed, the list of machinery/ equipments being placed in field laboratory and the location of field laboratory along with the Programme. The Engineer shall cause these details to be verified at each appropriate stage of the programme.
- 23.3 An update of the Programme shall be a programme showing the actual progress achieved on each activity and the effect of the progress achieved on the timing of the remaining Works, including any changes to the sequence of the activities.
- 23.4 The Contractor shall submit to the Engineer for approval an updated Programme at intervals no longer than the period stated in the Contract Data. If the Contractor does not submit an updated Programme within this period, the Engineer may withhold the amount stated in the Contract Data from the next payment certificate and continue to withhold this amount until the next payment after the date on which the overdue Programme has been submitted.
- 23.5 The Engineer's approval of the Programme shall not alter the Contractor's obligations. The Contractor may revise the Programme and submit it to the Engineer again at any time. A revised Programme shall show the effect of Variations and Compensation Events.

24. Extension Of Time In Contracts :

Subject to any requirement in the contract as to completion of any portions or portions of the works before completion of the whole, the contractor shall fully and finally complete the whole of the works comprised in the contract (with such modifications as may be directed under conditions of this contract) by the date entered in the contract or extended date in terms of the following clauses:

- a) Extension attributable to M. C. G. M.**
- (i) **Extension Due To Modification:** If any modifications have been ordered which in the opinion of the Engineer have materially increased the magnitude of the work, then such extension of the contracted date of completion may be granted as shall appear to the Engineer to be reasonable in the circumstances, provided moreover that the Contractor shall be responsible for requesting such extension of the date as may be considered necessary as soon as the cause thereof shall arise and in any case **should not be less than 30 days before the expiry of the date fixed for completion of the works.**
- (ii) **Extension For Delay Due To BMC:** In the event of any failure or delay by the BMC to hand over the Contractor possession of the lands necessary for the execution of the works or to give the necessary notice to commence the works or to provide the

necessary drawings or instructions or any other delay caused by the BMC due to any other cause whatsoever, then such failure or delay shall in no way affect or vitiate the contract or alter the character thereof or entitle the contractor to damages or compensation therefore, but in any such case, the BMC may grant such extension(s) of the completion date as may be considered reasonable.

Note: For extension of time period as governed in (i) and (ii) above, any modifications in design/drawings, specifications, quantities shall be needed to be justified with recorded reasons with approval of Ch. Eng. for not anticipating the same while preparing estimates and draft tender.

(b) Extension Of Time For Delay Due To Contractor : The time for the execution of the work or part of the works specified in the contract documents shall be deemed to be the essence of the contract and the works must be completed no later than the date(s) / the programme for completion of work as specified in the contract. If the contractor fails to complete the works within the time as specified in the contract for the reasons other than the reasons specified in above as (a.i) and (a.ii), the BMC may, if satisfied that the works can be completed by the contractor within reasonable short time thereafter, allow the contractor for further extension of time as the Engineer may decide. On such extension the BMC will be entitled without prejudice to any other right and remedy available on that behalf, to recover the compensation as governed by Clause 8 (e) of GCC.

For the purpose of this Clause, the contract value of the works shall be taken as value of work as per contract agreement including any supplementary work order / contract agreement issued.

Further, competent authority while granting extension to the currency of contract under Clause (b) of as above may also consider levy of penalty, as deemed fit based on the merit of the case. Also, the reasons for granting extension shall be properly documented.

25. Delays Ordered by the Engineer

25.1 The Engineer may instruct the Contractor to delay the start or progress of any activity within the Works. Delay/delays totaling more than 30 days will require prior written approval of the DMC/AMC.

26. Management Meetings

26.1 The Engineer may require the Contractor to attend a management meeting. The business of a management meeting shall be to review the plans for progress of the Works.

26.2 The Engineer shall record the business of management meetings and provide copies of the record to those attending the meeting. The responsibility of the parties for actions to be taken shall be decided by the Engineer either at the management meeting or after the management meeting and stated in writing to all those who attended the meeting.

C. Quality Control

27.1 **Work to be open to Inspection and Contractor or Responsible agent to be present**

All works under or in course of execution or executed in pursuance of the contract shall at all times be open to the inspection and supervision of the Eng-in-charge and his subordinates and the contractor shall at all times during the usual working hours, at all other times, during the usual working hours and at all other times at which reasonable notice of the intention of the Eng-in-charge and his subordinates to visit the works shall have been given to the contractor, either himself be present to receive orders and instruction or have responsible agent duly accredited in writing present for that purpose. Order given to the contractors' duly authorized agent shall be considered to have the same force and effect as if they had been given to the contractor himself.

27.2 Notice To Be Given Before Work Is Covered Up

The contractor shall give not less than ten days' notice in writing to the Eng-In-Charge or his subordinate in charge of the work before covering up or otherwise placing beyond the reach of measurement any work in order that the same may be measured and correct dimension thereof taken before the same is so covered up or placed beyond the reach of measurements and shall not cover up or place beyond the reach of measurement any work without the consent in writing of the Eng-In-Charge or his subordinate in charge of the work, and if any work shall be covered up or placed beyond the reach of measurement, without such notice having been given or consent obtained the same shall be uncovered at the contractors expenses, and in default thereof no payment or allowance shall be made for such work or for the materials with which the same was executed

27.3 Works to be executed in accordance with specifications / drawings / orders etc. :

The contractor shall execute the whole and every part of the work the most substantial and workman like manner and both has regards material and every other respect in strict accordance with specifications. The contractor shall also confirm exactly, fully and faithfully to the designs, drawings and instructions in writing relating to the work signed by the Engineer In-charge and lodged in his office and to which the contractor shall be entitled to have access for the purpose of inspection at such office, or on the site or work during office hours. The contractor shall be entitled to receive three sets of contract drawings and working drawings as well as one certified copy of the accepted tender along with the work order free of cost.

27.4 ~~Ready Mix Concrete/ Asphalt Mix~~

- ~~i) The contractor shall have to arrange Ready Mix concrete (RMC)/Asphalt from RMC/ASPHALT producing plants registered with BMC~~
- ~~ii) The contractor shall, within a 7 days of award of the work, submit a list of at least three RMC/Asphalt producers with details of such plants including details and number of transit, mixers & pumps etc. to be deployed indicating name of owner/company, its location, capacity, technical establishment.~~

~~The Engineer in-charge will reserve right to inspect at any stage and reject the concrete if he is not satisfied about quality of product at the user's end.~~
- ~~iii) The Engineer in-charge reserves the right to exercise control over the:-~~

- a) ~~Calibration check of the RMC/Asphalt plant.~~
- b) ~~Weight and quantity check on the ingredients, water and admixtures added for batch mixing for RMC plants.~~
- e) ~~Time of mixing of concrete/grade of asphalt.~~
- d) ~~Testing of fresh concrete/asphalt mix, recording of results and declaring the mix fit or unfit for use. This will include continuous control on the work ability during production and taking corrective action, if required.~~
- e) ~~For exercising such control, the Engineer-in-charge shall periodically depute his authorized representative at the RMC/Asphalt plant. It shall be responsibility of the contractor to ensure that all necessary equipment, manpower & facilities are made available to Engineer-in-charge and or his authorized representative at RMC / Asphalt plant.~~
- f) ~~All required relevant records of RMC/Asphalt mix shall be made available to the Engineer-in-charge or his authorized representative. Engineer-in-charge shall, as required, specify guidelines & additional procedures for quality control & other parameters in respect of material production & transportation of concrete mix which shall be binding on the contractor & the RMC/Asphalt plant. Only concrete as approved in design mix by Engineer-in-charge shall be produced in RMC plant and transported to the site.~~
- g) ~~The contractor shall have to produce a copy of chalan receipts/SCADA reports/VTS reports as issued by the RMC/Asphalt plant as a documentary proof in lieu of supply of RMC/Asphalt mix before releasing payment.~~

28. Identifying Defects

- 28.1 The Engineer shall check the Contractor's work and notify the Contractor of any Defects that are found. Such checking shall not affect the Contractor's responsibilities. The Engineer may instruct the Contractor to search for a Defect and to uncover and test any work that the Engineer considers may have a Defect.
- 28.2 The Contractor shall permit the Employer's technical person(s) to check the Contractor's work and notify the Engineer and Contractor if any defects that are found.

29. Tests (If applicable)

- 29.1 For carrying out mandatory tests as prescribed in the specifications, the Contractor shall establish field laboratory at the location decided by Engineer. The field laboratory will have minimum of equipments as specified in the Contract Data. The contractor shall be solely responsible for:
- a. Carrying out the mandatory tests prescribed in the Specifications, and
 - b. For the correctness of the test results, whether preformed in his laboratory or elsewhere.
- 29.2 If the Engineer instructs the Contractor to carry out a test not specified in the Specification/ Quality Assurance Handbook to check whether any work has a Defect and the test shows

that it does, the Contractor shall pay for the test and any samples. If there is no defect, the test shall be a compensation event.

When required by the Engineer-in-charge the contractor(s) shall supply for the purpose of testing samples of all materials proposed to be used in the works. Samples submitted either to govern bulk supplies or required for testing before use shall be in suitable packages to contain them and shall be provided free of charge by the contractor. The cost of testing shall be borne by the contractor even if the result of the sample confirm or do not confirm to the relevant BIS code specifications.

- i) All expenditure required to be incurred for taking the samples conveyance, packing shall be borne by the contractor himself.
- ii) The failed material shall be removed from the site by the contractor at his own cost within a week time of written order of the Engineer in-charge.

29.3 ~~Setting of Site Laboratories: (If applicable)~~

~~Contractors shall set up a laboratory at site before commencement of work at their cost for performing various tests and at least the following machines and equipments shall be provided therein—~~

- ~~1 Set of Sieves as per I.R.C./I.S.~~
- ~~2 Compressive Testing Machine(For new works)~~
- ~~3 Oven, Electrically Operated~~
- ~~4 Weighing Balancee (20 kg capacity)~~
- ~~5 3-m straight edge~~
- ~~6 Sieve shaker~~
- ~~7 First Aid Box~~
- ~~8 Measuring Jar (for silt content)~~
- ~~9 Other Machines/apparatus as may be directed by the Engineer~~
- ~~10 Vernier Caliber~~
- ~~11 Level/Theodolite~~

~~All the test records shall be maintained in the site office and made available as and when required. The laboratory must be established within 15 days from the date of receipt of the orders from Engineer In charge. On failure to do so, a penalty of Rs 1000/- per day shall be imposed.~~

~~The contractor shall install testing equipment at site. The contractor shall ensure and certify the calibration of the equipment so installed and shall maintain the same in working order throughout the period of construction. The contractor shall also provide necessary technically qualified experienced trained staff for carrying out such tests for using such equipment. The tests shall be carried out under the supervision of the Engineer-in-charge. The calibration shall be checked every twelve months as directed by Engineer-in-charge.~~

30. Correction of Defects noticed during the Defects Liability Period.

- 30.1 (a) The Engineer shall give notice to the Contractor of any Defects before the end of the Defects Liability Period, which begins at Completion and ends after three years. The Defects Liability Period shall be extended for as long as Defects remain to be corrected.
- (b) Every time notice of Defect/Defects is given, the Contractor shall correct the notified Defect/Defects within the duration of time specified by the Engineer's notice.
- (c) The Engineer may issue notice to the Contractor to carry out removal of defects or deficiencies, if any, noticed in his inspection, or brought to his notice. The Contractor shall remove the defects and deficiencies within the period specified in the notice and submit to the Engineer a compliance report.

31. Uncorrected Defects and Deficiencies

- 31.1 If the Contractor has not corrected a Defect pertaining to the Defect Liability Period under clause and deficiencies in maintenance, to the satisfaction of the Engineer, within the time specified in the Engineer's notice, the Engineer will assess the cost of having the Defect or deficiency corrected, and the Contractor shall pay this amount, on correction of the Defect or deficiency by another agency.

D. Cost Control

32. Variations

The Engineer shall, having regard to the scope of the Works and the sanctioned estimated cost, have power to order, in writing, Variations within the scope of the Works he considers necessary or advisable during the progress of the Works. Such Variations shall form part of the Contract and the Contractor shall carry them out and include them in updated Programmes produced by the Contractor. Oral orders of the Engineer for Variations, unless followed by written confirmation, shall not be taken into account.

33. Payments for Variations

- 33.1 If rates for Variation items are specified in the Bill of Quantities, the Contractor shall carry out such work at the same rate.
- 33.2 The rate for Extra / Excess shall be governed by clause 10.A of Standard General Condition of Contract

34. Cash Flow Forecasts

When the Programme is updated, the Contractor shall provide the Engineer with an updated cash flow forecast.

35. Payment Certificates

The payment to the Contractor will be as follows for construction work:

- a) A bill shall be submitted by the Contractor monthly or before the date fixed by the Engineer In-charge for all works executed in the previous month, and the Engineer In-charge shall take or cause to be taken requisite measurement for the purpose of having the same verified and the claim, so far as it is admissible, shall be adjusted, if possible, within 10 days from the presentation of the bill. If the contractor does not submit the bill within the time fixed as aforesaid, the Engineer In-charge may depute a subordinate to measure up the said work in the presence of the contractor or his duly authorized agent whose counter signature to the measurement list shall be sufficient

warrant, and Engineer In-Charge may prepare a bill from such list which shall be binding on the contractor in all respects.

- b) The Engineer shall check the Contractor's fortnightly/monthly statement within 14 days and certify the amount to be paid to the Contractor.
- c) The value of work executed shall be determined, based on measurements by the Engineer.
- d) The value of work executed shall comprise the value of the quantities of the items in the Bill of Quantities completed.
- e) The value of work executed shall also include the valuation of Variations and Compensation Events.
- f) The Engineer may exclude any item certified in a previous certificate or reduce the proportion of any item previously certified in any certificate in the light of later information.
- g) The contractor shall submit all bills on the printed forms at the office of Engineer In-charge. The charges to be made in the bills shall always be entered at the rates specified in tender.

36. Payments

- 36.1 Payments shall be adjusted for deductions for advance payments, retention, security deposit, other recoveries in terms of the Contract and taxes at source, as applicable under the law. The Employer shall pay the Contractor the amounts certified by the Engineer within 15 days of the date of each certificate.
- 36.2 All sums payable by a contractor by way of compensation under any of these conditions, shall be considered as a reasonable compensation to be applied to the use of BMC without reference to the actual loss or damage sustained and whether any damage has or has not been sustained.
- 36.3 No payment shall be made for any work estimated to cost less than Rupees One Thousand till after the whole of work shall have been completed and the certificate of completion given. But in the case of works estimated to cost more than Rs. One Thousand, the contractor shall on submitting a monthly bill therefore be entitled to receive payment proportionate to the part of the work than approved and passed by the Engineer In-charge, whose certificate of such approval and passing of the sum so payable shall be final and conclusive against the contractor. All such intermediate payments shall be regarded as payments by way of advance against the final payments only and not as payments for work actual done and completed and shall not preclude the Engineer In-charge from requiring any bad, unsound, imperfect or unskillful work to be removed or taken away and reconstructed or re-erected nor shall any such payment be considered as an admission of the due performance of the contract or any part thereof in any respect or the offering of any claim not shall it conclude, determine or effect in any other way, the powers of the Engineer In-charge as to the final settlement and adjustment of the accounts or otherwise, or in any other way vary or effect the contract. The final bill shall be submitted by the Contractor within one month of the date fixed for the completion of the work otherwise the Engineer In-charge's certificate of the measurements and of the total amount payable for the work shall be final and binding on all parties.

37. The Contractor shall not be entitled to compensation to the extent that the Employer's interests are adversely affected by the Contractor for not having given early warning or not having cooperated with the Engineer.

38. Tax

(i) The tenderer shall quote inclusive of all taxes other than GST (Excluding GST), Levies, Duties, Cess etc as applicable at the time of bid submission. GST as applicable shall be paid separately on submission of bills/invoice.

Input Tax Credit of GST as available with the bidder will not be claim separately by BMC. However, while quoting the rates benefit of Input Tax Credit or Exemptions shall be passed on to the BMC by way of equivalent reduction in quoted price.

(ii) "Chapter XXI-Miscellaneous, section 171(1) of GST Act, 2017 governs the 'Anti Profiteering Measure' (APM).

As per the provision of this section, 'Any reduction in rate of tax on any supply of goods or services or the benefit of input tax credit shall be passed on to the recipient by way of commensurate reduction in prices'

Accordingly, the contractor should pass on the complete benefit accruing to him on account of reduced tax rate or additional input tax credit, to BMC.

Further, all the provisions of GST Act will be applicable to the tender."

39. Currencies

All payments will be made in Indian Rupees.

40. Liquidated Damages

Both, the Contractor and the Employer have agreed that it is not feasible to precisely estimate the amount of losses due to delay in completion of works and the losses to the public and the economy, therefore, both the parties have agreed that the Contractor shall pay liquidated damages to the Employer and not by way of penalty, at the rate per week or part thereof stated in the Contract Data for the period that the Completion Date is later than the Intended Completion Date. Liquidated damages at the same rates shall be withheld if the Contractor fails to achieve the milestones prescribed in the Contract Data. However, in case the Contractor achieves the next milestone, the amount of the liquidated damages already withheld shall be restored to the Contractor by adjustment in the next payment certificate. The Employer and the contractor have agreed that this is a reasonable agreed amount of liquidated damage. The Employer may deduct liquidated damages from payments due to the Contractor. Payment of liquidated damages shall not affect the Contractor's other liabilities.

41. Cost of Repairs

Loss or damage to the Works or Materials to be incorporated in the Works between the Start Date and the end of the Defects Correction periods shall be remedied by the Contractor at his cost if the loss or damage arises from the Contractor's acts or omissions

E. Finishing the Contract

42. Completion of Construction and Maintenance

42.1 The Contractor shall request the Engineer to issue a certificate of completion of the construction of the works, and the Engineer will do so upon deciding that the works is completed. This shall be governed as per clause no.8 (g) of Standard General Conditions of Contract.

43. Taking Over

43.1 The Employer shall take over the works within seven days of the Engineer issuing a certificate of completion of works. The Contractor shall continue to remain responsible for its routine maintenance during the maintenance period if specified in the contract.

44. Final Account

~~Final joint measurement alongwith the representatives of the contractor should be taken recorded and signed by the Contractors.~~ Contractors should submit the final bill within 1 month of physical completion of the work.

If the contractor fails to submit the final bill within 1 month, the BMC staff will prepare the final bill based on the joint measurement within next 3 months.

Engineer's decision shall be final in respect of claims for defect and pending claims against contractors.

No further claims should be made by the Contractor after submission of the final bill and these shall be deemed to have been waived and extinguished. Payment of those items of the bills in respect of which there is no dispute and of items in dispute, for quantities and rates as approved by the Commissioner shall be made within a reasonable period as may be necessary for the purpose of verification etc.

After payment of the final bill as aforesaid has been made, the contractor may, if he so desires, reconsider his position in respect of a disputed portion of the final bills and if he fails to do so within 84 days, his disputed claim shall be dealt with as provided in the contract.

A percentage of the retention money, over and above the actual retention money as indicated below shall be held back from payments till the finalization of final bill to be submitted as per above and will be paid within 30 days of acceptance of the final bill.

Sr. No	Amount of Contract Cost	Minimum Payable Amount in final bill
1	Upto Rs.5 Crs.	Rs.10 Lacs or final bill whichever is more

2	Upto Rs.25 Crs.	Rs.1 Crore or final bill amount whichever is more
3	Upto Rs.50 Crs.	Rs.2 Crores or final bill amount whichever is more
4	Upto Rs.100 Crs.	Rs.4 Crore or final bill amount whichever is more
5	More than Rs.100 Crs.	Rs.7 Crore or final bill amount whichever is more

The contractor have to submit the bill for the work carried out within 15 days from the date of completion of the work to the respective executing department. If the contractor fails to submit their bills to concerned executing department, penalty or action as shown below will be taken for each delayed bill:-

After 15 days from the date of completion / running bill upto certain date, upto next 15 days i.e. up to 30 days	Equal to 5% of bill amount
Next 15 days upto 45 days from the date of completion / running bill upto specified date	Equal to 10% of bill amount
If not submitted witin 45 days from the date of completion / R.A. bill	Bill will not be admitted for payment.

45.0 Operating and Maintenance Manuals

- 45.1 If "as built" Drawings and/or operating and maintenance manuals are required, the Contractor shall supply them by the dates stated in the Contract Data.
- 45.2 If the Contractor does not supply the Drawings and/or manuals by the dates stated in the Contract Data, or they do not receive the Engineer's approval, the Engineer shall withhold the amount stated in the Contract Data from payments due to the Contractor.

46. Termination

- 46.1 The Employer or the Contractor may terminate the Contract if the other party causes a fundamental breach of the Contract.
- 46.2 Fundamental breaches of Contract shall include, but shall not be limited to, the following
- a) the Contractor stops work for 30 days when no stoppage of work is shown on the current Programme and the stoppage has not been authorized by the Engineer;
 - b) the Contractor is declared as bankrupt or goes into liquidation other than for approved reconstruction or amalgamation;
 - c) the Engineer gives Notice that failure to correct a particular Defect is a fundamental breach of Contract and the Contractor fails to correct it within a reasonable period of time determined by the Engineer;
 - d) the Contractor does not maintain a Security, which is required;
 - e) the Contractor has delayed the completion of the Works by the number of days for

which the maximum amount of liquidated damages can be paid, as defined in relevant clause.

- f) the Contractor fails to provide insurance cover as required under relevant clause
- g) if the Contractor, in the judgment of the Employer, has engaged in the corrupt or fraudulent practices as defined in GCC in competing for or in executing the Contract.
- h) if the Contractor fails to set up a field laboratory with the prescribed equipment, within the period specified in the Contract Data; and
- i) any other fundamental breaches as specified in the Contract Data.
- j) if the Contractor fails to deploy machinery and equipment or personnel as specified in the Contract Data at the appropriate time.

46.3 When either party to the contract gives notice of a breach of contract to the Engineer for a cause other than those listed above, the Engineer shall decide whether the breach is fundamental or not.

46.4 Notwithstanding the above, the Employer may terminate the Contract for convenience.

46.5 If the Contract is terminated, the Contractor shall stop work immediately, make the Site safe and secure, and leave the Site as soon as reasonably possible

47. Payment upon Termination

47.1 If the Contract is terminated because of a fundamental breach of Contract by the Contractor, the Engineer shall issue a certificate for value of the work done and materials ordered less liquidated damages, if any, less advance payments received up to the date of the issue of the certificate and less the percentage to apply to the value of the work not completed, as indicated in the Contract Data. If the total amount due to the Employer exceeds any payment due to the Contractor, the difference shall be recovered from the security deposit, and performance security. If any amount is still left un-recovered it will be a debt due from the Contractor to the Employer

47.2 If the Contract is terminated at the Employer's convenience, the Engineer shall issue a certificate for the value of the work done, the reasonable cost of removal of Equipment, repatriation of the Contractor's personnel employed solely on the Works, and the Contractor's costs of protecting and securing the Works and less advance payments received up to the date of the certificate, less other recoveries due in terms of the Contract, and less taxes due to be deducted at source as per applicable law

48. Property

48.1 All Materials on the Site, Plant, Equipment, Temporary Works, and Works shall be deemed to be the property of the Employer for use for completing balance construction work if the Contract is terminated because of the Contractor's default, till the Works is completed after which it will be transferred to the Contractor and credit, if any, given for its use.

49. Release from Performance

If the Contract is frustrated by the outbreak of war or by any other event entirely outside the control of the Employer or the Contractor, the Engineer shall certify that the Contract has been frustrated. The Contractor shall make the Site safe and stop work as quickly as possible after receiving this certificate and shall be paid for all work carried out before

receiving it and for any work carried out afterwards to which a commitment was made.

E) Other Conditions of Contract

50. Labour

- 50.1 The Contractor shall, unless otherwise provided in the Contract, make his own arrangements for the engagement of all staff and labour, local or other, and for their payment, housing, feeding and transport.
- 50.2 The Contractor shall, if required by the Engineer, deliver to the Engineer a return in detail, in such form and at such intervals as the Engineer may prescribe, showing the staff and the number of the several classes of labour from time to time employed by the Contractor on the Site and such other information as the Engineer may require.

51. Compliance with Labour Regulations

- (a) During continuance of the Contract, the Contractor and his sub-Contractors shall abide at all times by all existing labour enactments and rules made there under, regulations, notifications and bye laws of the State or Central Government or local authority and any other labour law (including rules), regulations, bye laws that may be passed or notification that may be issued under any labour law in future either by the State or the Central Government or the local authority.
- (b) Furthermore, the Contractor shall keep the Employer indemnified in case any action is taken against the Employer by the competent authority on account of contravention of any of the provisions of any Act or rules made there under, regulations or notifications including amendments. If the Employer is caused to pay or reimburse, such amounts as may be necessary to cause or observe, or for non-observance of the provisions stipulated in the notifications / bye laws / Acts / Rules / regulations including amendments, if any, on the part of the Contractor, the Engineer/Employer shall have the right to deduct any money due to the Contractor including his amount of performance guarantee. The Employer/Engineer shall also have right to recover from the Contractor any sum required or estimated to be required for making good the loss or damage suffered by the Employer.
- (c) The Contractor shall require his employees to obey all applicable laws, including those concerning safety at work.
- (d) The employees of the Contractor and the Sub-Contractor in no case shall be treated as the employees of the Employer at any point of time.

52. Drawings and Photographs of the Works

- 52.1 The Contractor shall do photography/video photography of the site firstly before the start of the work, secondly mid-way in the execution of different stages of work as required by Engineer In-charge and lastly after the completion of the work. No separate payment will be made to the Contractor for this.

52.2 The Contractor shall not disclose details of Drawings furnished to him and works on which he is engaged without the prior approval of the Engineer in writing. No photograph of the works or any part thereof or plant employed thereon, except those permitted under above clause, shall be taken or permitted by the Contractor to be taken by any of his employees or any employees of his sub-Contractors without the prior approval of the Engineer in writing. No photographs/ Video photography shall be published or otherwise circulated without the approval of the Engineer in writing.

53. The Apprentices Act, 1961

The Contractor shall duly comply with the provisions of the Apprentices Act 1961 (III of 1961), the rules made there under and the orders that may be issued from time to time under the said Act and the said Rules and on his failure or neglect to do so, he shall be subject to all liabilities and penalties provided by the said Act and said Rules.

54. Contract Document

The documents forming the contract are to be taken as mutually explanatory of one another. Unless otherwise provided in the contract, the priority of the documents forming the contract shall be, as follows:

1)	Contract Agreement (if completed)
2)	The letter of Acceptance
3)	The Bid:
4)	Addendum to Bid; if any
5)	Tender Document
6)	The Bill of Quantities:
7)	The Specification:
8)	Detailed Engineering Drawings
9)	Standard General Conditions of Contracts (GCC)
10)	All correspondence documents between bidder/contractor and BMC.

55. Conflict of Interest

The Applicant shall not have a conflict of interest (the “Conflict of Interest”) that affects the Bidding Process. Any Applicant found to have a Conflict of Interest shall be disqualified. An Applicant shall be deemed to have a Conflict of Interest affecting the Bidding Process, if

1	A constituent of such Applicant is also a constituent of another Applicant; or
2	Such Applicant has the same legal representative for purposes of this Application as any other Applicant; or
3	Such Applicant, or any Associate thereof has a relationship with another Applicant, or any Associate thereof, directly or through common third party/ parties, that puts either

	or both of them in a position to have access to each other’s information about, or to influence the Application of either or each other; or
4	The Applicant shall be liable for disqualification if any legal, financial or technical adviser of the Authority in relation to the Project is engaged by the Applicant, its Member or any Associate thereof, as the case may be, in any manner for matters related to or incidental to the Project. For the avoidance of doubt, this disqualification shall not apply where such adviser was engaged by the Applicant, its Member or Associate in the past but its assignment expired or was terminated 6 (six) months prior to the date of issue of this TENDER. Nor will this disqualification apply where such adviser is engaged after a period of 3 (three) years from the date of commercial operation of the Project.

56. Applications and costs thereof

No Applicant shall submit more than one Application for the Project. An applicant applying individually shall not be entitled to submit another application either individually. The Applicant shall be responsible for all of the costs associated with the preparation of their Applications and their participation in the Bid Process. The Authority will not be responsible or in any way liable for such costs, regardless of the conduct or outcome of the Bidding Process.

57. Acknowledgment by Applicant

It shall be deemed that by submitting the Application, the Applicant has:

a.	made a complete and careful examination of the tender;
b.	received all relevant information requested from the Authority;
c.	accepted the risk of inadequacy, error or mistake in the information provided in the tender or furnished by or on behalf of the Authority relating to any of the matters referred; and
d.	Agreed to be bound by the undertakings provided by it under and in terms hereof. “The Authority” shall not be liable for any omission, mistake or error in respect of any of the above or on account of any matter or thing arising out of or concerning or relating to the TENDER or the Bidding Process, including any error or mistake therein or in any information or data given by the Authority.

58. Right to accept or reject any or all Applications/ Bids

Notwithstanding anything contained in this TENDER, “The Authority” reserves the right to accept or reject any Application and to annul the Bidding Process and reject all Applications/ Bids, at any time without any liability or any obligation for such acceptance, rejection or annulment, and without assigning any reasons therefore. In the event that the Authority rejects or annuls all the Bids, it may, in its discretion, invite all eligible Bidders to submit fresh Bids hereunder.

“The Authority” reserves the right to reject any Application and / or Bid if:

(a)	at any time, a material misrepresentation is made or uncovered, or
(b)	the Applicant does not provide, within the time specified by the Authority, the supplemental information sought by the Authority for evaluation of the Application.

In case it is found during the evaluation or at any time before signing of the Agreement or after its execution and during the period of subsistence thereof including the concession thereby granted by “The Authority”, that one or more of the pre-qualification conditions have not been met by the Applicant, or the Applicant has made material misrepresentation or has given any materially incorrect or false information, the Applicant shall be disqualified forthwith if not yet appointed as the Successful Bidder either by issue of the LOA (Letter of Approval) or entering into of the Agreement, and if the Applicant has already been issued the LOA or has entered into the Concession Agreement, as the case may be, the same shall, notwithstanding anything to the contrary contained therein or in this TENDER, be liable to be terminated, by a communication in writing by “The Authority” to the Applicant, without the Authority being liable in any manner whatsoever to the Applicant and without prejudice to any other right or remedy which the Authority may have under this TENDER, the Bidding Documents, the Concession Agreement or under applicable law. “The Authority” reserves the right to verify all statements, information and documents submitted by the Applicant in response to the TENDER. Any such verification or lack of such verification by the Authority shall not relieve the Applicant of its obligations or liabilities hereunder nor will it affect any rights of the Authority there under.

59. The bid shall be rejected if the bidder-

a.	Stipulates the validity period less than 180 days.
b.	Stipulates own condition /conditions.
c.	Does not fill and (digital) sign undertaking forms, which are incorporated, in the document.

60. Clarifications

Applicants requiring any clarification on the tender may notify “the Authority” in writing or by fax or e-mail. They should send in their queries before the date specified in the header data. “The Authority” shall Endeavor to respond to the queries within the period specified therein. The responses will be sent by fax and/or e-mail. The Authority will forward all the queries and its responses thereto, to all purchasers of the TENDER without identifying the source of queries.

“The Authority” shall Endeavor to respond to the questions raised or clarifications sought by the Applicants. However, the Authority reserves the right not to respond to any question or provide any clarification, in its sole discretion, and nothing in this Clause shall be taken or read as compelling or requiring the Authority to respond to any question or to provide any clarification, but not later than the date provided in header data.

“The Authority” may also on its own motion, if deemed necessary, issue interpretations and

clarifications to all Applicants. All clarifications and interpretations issued by the Authority shall be deemed to be part of the tender. Verbal clarifications and information given by Authority or its employees or representatives shall not in any way or manner be binding on the Authority.

61. Amendment of tender

At any time prior to the deadline for submission of Application, the Authority may, for any reason, whether at its own initiative or in response to clarifications requested by an Applicant, modify the tender by the issuance of Addendum.

Any Addendum thus issued will be sent in writing/ Fax/ Email to all those who have purchased the tender.

In order to afford the Applicants a reasonable time for taking an Addendum into account, or for any other reason, the Authority may, in its sole discretion, extend the Application Due Date.

Preparation and Submission of Application

62. Language

The Application and all related correspondence and documents in relation to the Bidding Process shall be in English language. Supporting documents and printed literature furnished by the Applicant with the Application may be in any other language provided that they are accompanied by translations of all the pertinent passages in the English language, duly authenticated and certified by the Applicant. Supporting materials, which are not translated into English, may not be considered. For the purpose of interpretation and evaluation of the Application, the English language translation shall prevail.

63. Format and signing of Application

The Applicant shall provide all the information sought under this TENDER. The Authority will evaluate only those Applications that are received in the required formats and complete in all respects. Incomplete and /or conditional Applications shall be liable to rejection.

The Applicant will upload bid in One Folder in electronic form which shall contain the scanned certified copies of the documents given below and the documents uploaded has to be digitally signed by the bidder. These copies shall be certified by Practicing Notary approved by the Govt. of Maharashtra or Govt. of India with his stamp, clearly stating his name & registration number, except where original documents are demanded

64. Marking of Applications

The Applicant shall submit the Application in the format specified at Appendix-I, together with the documents, upload in folder as “VENDOR” together with their respective enclosures

Applications submitted by fax, telex, telegram shall not be entertained and shall be rejected outright.

65. Late Applications

Applications received by the Authority after the specified time on the Application Due Date shall not be eligible for consideration and shall be summarily rejected.

66. Confidentiality

Information relating to the examination, clarification, evaluation, and recommendation for the short-listed qualified Applicants shall not be disclosed to any person who is not officially concerned with the process or is not a retained professional advisor advising the Authority in relation to or matters arising out of, or concerning the Bidding Process. The Authority will treat all information, submitted as part of Application, in confidence and will require all those who have access to such material to treat the same in confidence. The Authority may not divulge any such information unless it is directed to do so by any statutory entity that has the power under law to require its disclosure or is to enforce or assert any right or privilege of the statutory entity and/ or the Authority or as may be required by law or in connection with any legal process.

67. Clarification Of Financial Bids

To assist in the examination, evaluation and comparison of Bids, the Engineer may, at his discretion, ask any bidder for clarification of his Bid, including breakdown of unit rates. The request for clarification and the response shall be in writing or by post/facsimile/e-mail. No Bidder shall contact the Engineer on any matter relating to his bid from the time of the bid opening to the time the contract is awarded. Any effort by the Bidder to influence the Engineer in the Engineer's bid evaluation, bid comparison or contract award decisions may result in the rejection of the Bidder's bid.

68. Inspection of site and sufficiency of tender:

- 1 The Contractor shall inspect and examine the site and its surrounding and shall satisfy himself before submitting his tender as to the nature of the ground and subsoil (so far as is practicable), the form and nature of the site, the quantities and nature of the work and materials necessary for the completion of the works and means of access to the site, the accommodation he may require and in general shall himself obtain all necessary information as to risk, contingencies and other circumstances which may influence or affect his tender. He shall also take into consideration the hydrological and climatic conditions.
- 2 The Employer may make available to the Contractor data on hydrological and sub- surface conditions as obtained by or on his behalf from investigations relevant to the works but the Contractor shall be responsible for his own interpretation thereof. The contractor shall engage his investigating agency with prior approval of the Engineer from the approved list of such agencies by BMC or Govt at his cost initially before commencing actual work and which shall be reimbursed immediately subject to satisfaction of the Engineer for faithful compliance and submission of required data regarding such investigation within specified time.
3. The Contractor shall be deemed to have satisfied himself before tendering as to the correctness and sufficiency of his tender for the works and of the rates and prices quoted in the schedule of works / items / quantities, or in Bill of Quantities, which rates and prices shall, except as otherwise provided cover all his obligations under the Contract and all matters and things necessary for proper completion and maintenance of the works. No extra charges consequent on any misunderstanding.

4. **Not Foreseeable Physical Obstructions or Conditions:** If, however, during the execution of the Works the Contractor encounters physical obstructions or physical conditions, other than climatic conditions on the Site, which obstructions or conditions were, in his opinion, not foreseeable by an experienced contractor, the Contractor shall forthwith give notice thereof to the Engineer. On receipt of such notice, the Engineer shall, if in his opinion such obstructions or conditions could not have been reasonably foreseen by an experienced contractor, after due consultation with the Contractor, determine:

- any extension of time to which the Contractor is entitled and
- The amount of any costs which may have been incurred by the Contractor by reason of such obstructions or conditions having been encountered, which shall be added to the Contract Price
- and shall notify the Contractor accordingly. Such determination shall take account of any instruction which the Engineer may issue to the Contractor in connection therewith, and any proper and reasonable measures acceptable to the Engineer which the Contractor may take in the absence of specific instructions from the Engineer. However such costings shall be got approved by the competent authority as governed vide rules prevailing with authority.

5. **Office for the Engineer (Works costing upto Rs.50 Lakhs)**

~~The Contractor shall at his own cost and to satisfaction of the Engineer provide a small temporary office, at the work-site which will include tables, chairs and lockers for keeping the records. He shall also make necessary arrangements for drinking water, telephone with a pre-requisite of e-governance and electronic communication. These offices are not to be allowed on public roads without the written instruction of the Engineer. These offices should be preferably located within 50 to 500 m of the worksite. In case the office is more than 500m away from the worksite, the contractor is to provide conveyance for Municipal Staff.~~

6. **Office for the Engineer (Works costing above Rs.50 lakhs)**

~~The Contractor shall at his own cost and to satisfaction of the Engineer provide a temporary office at the work-site which will include tables, chairs and lockers for keeping the records. He shall also make necessary arrangements for drinking water, latrines, with doors, windows, locks, bolts and fastenings sufficient for security for the Engineer, and his subordinates, as close to the works from time to time in progress as can be conveniently arranged, and shall at his own cost furnish the office with such chairs, tables, lockers, locks and fastenings as may be required by the Engineer, and no expense of any kind in connection with the erection or upkeep of the offices or fittings shall be borne by the Corporation, but all such work shall be carried out by the Contractor and the expenses thereof defrayed by him. The Contractor shall also make water connections and fit up stand pipe with a bib tap at each office. The latrines and the water connections shall be subject to all the conditions herein elsewhere laid down for temporary water connection and latrines generally with all requisite equipments for e-governance and electronic and digital communication. These offices are not to be allowed on public roads without the written instruction of the Engineer. These offices should be preferably located within 50 to 500 m of the worksite. In case the office is more than 500m away from the worksite, the contractor is to provide~~

~~conveyance. Also, for staff working beyond working hours the contractor has to provide conveyance.~~

7. ~~Permission for provision & removal of office on completion of work~~

~~The tenderer shall obtain permission for provision of site office, cement go-down, store, etc. on payment of necessary cost implication. The cement go-down, Watchman cabins, etc. shall be provided as directed and shall be removed by the Tenderers on completion of the work at their cost. It is binding on the Tenderer to fulfill requirements of Environmental Authorities. The location of such office shall be finalized and got approved from the Engineer before erection / commencement work.~~

8. Contractor's office near works:

The Contractor shall have an office near the works at which notice from the Commissioner or the Engineer may be served and shall, between the hours of sunrise and sunset on all working days, have a clerk or some other authorized person always present at such office upon whom such notices may be served and service of any notices left with such clerk or other authorized person or at such office shall be deemed good service upon the Contractor and such offices shall have pre-requisite facilities fore-governance.

69. Official Secrecy:

The Contractor shall of all the persons employed in any works in connection with the contract that the India Official Secrets Act 1923 (XIX of 1923) applies to them and will continue to apply even after execution of the said works and they will not disclose any information regarding this contract to any third party. The contractor shall also bring into notice that, any information found to be leaked out or disclosed the concern person as well as the Contractor will be liable for penal action; further the Corporation will be at liberty to terminate the contract without notice.

70. Subsequent Legislation:

If on the day of submission of bids for the contract, there occur changes to any National or State stature, Ordinance, decree or other law or any regulation or By-laws or any local or other duly constituted authority or the introduction of any such National or State Statute, Ordinance, decree or by which causes additional or reduced cost to the Contractor, such additional or reduced cost shall, after due consultation with the Contractor, be determined by the concerned Engineering Department of BMC and shall be added to or deducted from the Contract Price with prior approval of competent authority and the concerned Engineering Department shall notify the Contractor accordingly with a copy to the Employer. BMC reserve the right to take decision in respect of addition/reduction of cost in contract.

71. Patent, Right and Royalties:

The contractor shall save harmless and indemnify the Corporation from and against all claims and proceedings for or on account of infringement of any Patent rights, design trademark or name of other protected rights in respect of any constructional plant, machine work, or material used for or in connection with the Works or any of them and from and against all claims, proceedings, damages, costs, charges and expenses whatsoever in respect thereof or in relation thereto. Except where otherwise specified, the contractor shall pay all tonnage and other royalties, rent and other payments or compensation, if any, for getting stone, sand, gravel, clay or other materials required for the works or any of them.

72. Payments, Tax and Claims:

● **The limit for unforeseen claims**

Under no circumstances whatever the contractor shall be entitled to any compensation from BMC on any account unless the contractor shall have submitted a claim in writing to the Eng-in-charge within 1 month of the case of such claim occurring.

● **No interest for delayed payments due to disputes, etc:**

It is agreed that the BRIHANMUMBAI MUNICIPAL CORPORATION or its Engineer or Officer shall not be liable to pay any interest or damage with respect of any moneys or balance which may be in its or its Engineer's or officer's hands owing to any dispute or difference or claim or misunderstanding between the Municipal Corporation of Greater Bombay or its Engineer or Officer on the one hand and the contractor on the other, or with respect to any delay on the part of the Municipal Corporation of Greater Bombay or its Engineer or Officers in making periodical or final payments or in any other respect whatever.

73. Settlement of Disputes:

● **Termination of contract for death**

If the Contractor is an individual or a proprietary concern and the individual or the proprietor dies and if the Contractor is a partnership concern and one of the legal representative of the individual Contractor or the proprietor of the proprietary concern and in case of partnership, the surviving partners, are capable of carrying out and completing the contract, the Commissioner shall be entitled to cancel the contract as to its uncompleted part without the Corporation being in any way liable to payment of any compensation to the estate of the deceased Contractor and or to the surviving partners of the Contractor's firm on account of the cancellation of the contract. The decision of the Commissioner that the legal representative of the deceased Contractor or surviving partners of the Contractor's firm cannot carry out and complete the contract shall be final and binding on the parties. In the event of such cancellation the Commissioner shall not hold estate of the deceased Contractor and or surviving partners of the Contractor's firm liable in damages for not completing the contract.

● **Settlement of Disputes:**

If any dispute or differences of any kind whatsoever other than those in respect of which, the decision of any person is, by the Contract, expressed to be final and binding) shall arise between the Employer and the Contractor or the Engineer and the Contractor in connection with or arising out of the Contract or carrying out of the Works (Whether during the progress of the Works or after their completion and whether before or after the termination, abandonment or breach of the Contract) it, the aggrieved party may refer such dispute within a period of 7 days to the concerned Addl. Municipal Commissioner who shall constitute a committee comprising of three officers i.e. concerned Deputy Municipal Commissioner or Director (ES&P), Chief Engineer other than the Engineer of the Contract and concerned Chief Accountant. The Committee shall give decision in writing within 60 days. Appeal on the Order of the Committee may be referred to the Municipal Commissioner within 7 days. Thereafter the Municipal Commissioner shall constitute a Committee comprising of three Addl. Municipal Commissioners including Addl. Municipal Commissioner in charge of Finance Department. The Municipal Commissioner within a period of 90 days after being requested to do so shall give written notice of committee's decision to the Contractor. Save as herein provided such decision in respect of every matter so referred shall be final and binding upon both parties until the completion of the works, and shall forthwith be given effect to by the Contractor who shall proceed with the works with due diligence, whether he requires arbitration as hereinafter provided or not. If the Commissioner has given written notice of the decision to the Contractor and no Claim to arbitration has been communicated within a period of 90 days from receipt of such notice the said decision shall remain final and binding upon the Contractor.

74. Arbitration and Jurisdiction:

If the Commissioner shall fail to give notice of the decision as aforesaid within a period of 90 days after being requested as aforesaid, or if the Contractor be dissatisfied with any such decision, then and in any such case the Contractor may within 90 days after receiving notice of such decision or within 90 days after the expirations of the first named period of 90 days (as the case may be) require that the matter or matters in dispute be referred to arbitration as hereinafter provided. All disputes or differences in respect of which the decision (if any) of the Commissioner has not become final and binding as aforesaid shall be finally settled by Arbitration as follows:

Arbitration shall be effected by a single arbitrator agreed upon the parties. The arbitration shall be conducted in accordance with the provisions of the Arbitration Act, 1996 or any statutory modifications thereof, and shall be held at such place and time within the limits of Brihan Mumbai as the arbitrator may determine. The decision of the arbitrator shall be final and binding upon the parties hereto and the expense of the arbitration shall be paid as may be determined by the arbitrator. Performance under the Contract shall, if reasonably be possible, continued during the arbitration proceedings and payment due to the Contractor by the Employer shall not be withheld unless they are the subject matter of arbitration proceedings. The said arbitrator shall have full power to open up, review and revise any decision, opinion, direction, certification or valuation of the Commissioner and neither party shall be limited in the proceedings before such arbitrator to the evidence or arguments put before the Commissioner for the purpose of obtaining his said decision. No decision given by the Commissioner in accordance with the foregoing provisions shall disqualify him from being called as a witness and giving evidence before the arbitrator on any matters

whatsoever relevant to the disputes or difference referred to the arbitrator as aforesaid. All awards shall be in writing and for claims equivalent to 5,00,000 or more such awards shall state reasons for amounts awarded. The expenditure of arbitration shall be paid as may be determined by arbitrator.

In case of any claim, dispute or difference arising in respect of a contract, the cause of action thereof shall be deemed to have arisen in Mumbai and all legal proceedings in respect of any claim, dispute or difference shall be instituted in a competent court in the City of Mumbai only.

75. Copyright:

The copyright of all drawings and other documents provided by the Contractor under the contract shall remain vested in the Contractor or his sub-contractors as the case may be the employer shall have a license to use such drawings and other documents in connection with the design, construction, operation, maintenance of the works. At any time the Employer shall have further license without additional payment to the Contractor to use any such drawings or documents for the purpose of making any improvement of the works or enlargement or duplication of any part thereof, provided that such improvement, enlargement, or duplication by itself or in conjunction with any other improvements, enlargements or duplications already made in accordance with the further license does not result in the duplication of the whole works.

76. Receipts to be signed in firm's name by any one of the partners:

Every receipt for money which may become payable or for any security which may become transferable to the Contractor under these present shall, if signed in the partnership name by any one of the partners, be a good and sufficient discharge to the Commissioner and Municipal Corporation in respect of the money or security purporting to be acknowledged thereby, and in the event of death of any of the partners during the pendency of this contract, it is hereby expressly agreed that every receipt by any one of the surviving partners shall, if so signed as aforesaid, be good and sufficient discharge as aforesaid provided that nothing in this clause contained shall be deemed to prejudice or effect any claim which the Commissioner or the Corporation may hereafter have against the legal representatives of any partners so dying or in respect of any breach of any of the conditions thereof, provided also that nothing in this clause contained shall be deemed prejudicial or affect the respective rights or obligations of the Contractors and of the legal representatives of any deceased Contractors interest.

77. Proprietary data

All documents and other information supplied by the Authority or submitted by an Applicant to the Authority shall remain or become the property of the Authority. Applicants are to treat all information as strictly confidential and shall not use it for any purpose other than for preparation and submission of their Application. The Authority will not return any Application or any information provided along therewith.

78. Correspondence with the Applicant

Save and except as provided in this TENDER, the Authority shall not entertain any correspondence with any Applicant in relation to the acceptance or rejection of any Application.

79. Price Variation Clause

The Contractor shall be reimbursed or shall refund to the Corporation as the case may be the variation in the value of the work carried out from time to time, depending on whether the prices of material and labour as a whole rise or fall, and the method adopted for such computations shall be as given below, it being clearly understood that the contractor shall have no claim for being reimbursed on the ground that the price of a particular material or group of materials have risen beyond the limits of the presumptions made in the following paras, however, no price variations shall be made applicable for contracts upto 12 months:

A) ~~Controlled materials: Price variations shall be permitted in respect of these materials the price level of which is controlled by the Government or its agency. The rate ruling on the date of submission of the tender shall be considered as the basic price of such material for adjustment. Any variation in this rate shall be considered for reimbursement to the contractor or refund to be claimed from the contractor as the case may be. The contractor shall, for the purpose of adjustment submit in original the relevant documents from the suppliers.~~

B) ~~Labour and other materials: For the purpose of this contract and for allowing reimbursement or refund on account of variation of prices of (i) labour, and (ii) materials other than materials mentioned in A above, computation will be based on the formula enunciated below which is based on the presumptions that :~~

- ~~i) The general price level of labour, rises or falls in proportion to the rise or fall of consumer price index number 9 (general) for working class in Mumbai.~~
- ~~ii) The general price level of materials rises or falls in proportion to rise or fall of whole-sale price index as published by 'Economic Adviser to Govt. of India'.~~
- ~~iii) And that the component of labour is to the extent of 30 percent of 88 percent and the component of materials is to the extent of 70 percent of 88 percent of the value of the work carried out. The remaining 12 percent being the presumptive profit of the contractor.~~

a) ~~Formula for Labour component:
$$VL = \frac{(0.88 R) \times 30}{100} \times \frac{(I - IO)}{IO}$$~~

b) ~~Formula for Material component :
$$VM = \frac{(0.88 R) \times 70 - C}{100} \times \frac{(W - WO)}{WO}$$~~

~~Where—~~

~~VL := Amount of price variation to be reimbursed or claimed as refund on account of general rise or fall of index referred to above.~~

~~I := Consumer Price Index number of working class for Mumbai (declared by the Commissioner of Labour and Director of Employment, Mumbai) applicable to the period under reference (base year ending 2004-05 as 100 i.e. new series of indices).~~

- ~~IO := Consumer price index number for working class for Mumbai (declared by the Commissioner of labour and Director of Employment, Mumbai) prevailing, on the day of 28 days prior to the date of submission of the tender.~~
- ~~VM := The amount of price variation to be reimbursed or claimed as refund on account of general rise or fall of wholesale price index for period under reference.~~
- ~~W := Average wholesale price index as published by Economic Adviser to Govt. of India applicable to the period under reference.~~
- ~~WO := Wholesale price index as stated above prevailing on the day of 28 days prior to the date of submission of the tender.~~
- ~~R := Total value of the work done during the period under reference as recorded in the Measurement Book excluding water charges and sewerage charges but including cost of excess in respect of item upto 50 percent~~
- ~~C := Total value of Controlled materials used for the works as recorded in Measurement Book & paid for at original basic rate plus the value of materials used.~~

- ~~i) The quantity of the Controlled material adopted in working out the value of 'C' shall be inclusive of permitted wastages as / if mentioned in specifications.~~
- ~~ii) The basic rate for the supply of controlled material shall be inclusive of all the components of cost of materials excluding transport charges incurred for bringing the material from place of delivery to the site.~~

~~Computations based on the above formula will be made for the period of each bill separately and reimbursement will be made to (when the result is plus) and refund will claimed from (when the result is minus) the contractor's next bill. The above formulae will be replaced by the formulae in Annexure-I as and when mentioned in special conditions of contract.~~

~~The operative period of the contract for application of price variation shall mean the period commencing from the date of commencement of work mentioned in the work order and ending on the date when time allowed for the work order and ending on the date when time allowed for the work specified in the contract for work expires, taking into consideration, the extension of time, if any, for completion of the work granted by Engineer under the relevant clause of the conditions of contract in cases other than those where such extension is necessitated on account of default of the contractor.~~

~~The decision of the Engineer as regards the operative period of the contract shall be final and binding on the contractors.~~

- ~~iii) Where there is no supply of controlled items to contractor the component 'C' shall be taken as zero.~~
- ~~C) Adjustment after completion: If the Contractor fails to complete the works within the time for completion adjustment of prices thereafter until the date of completion of the works shall be made using either the indices or prices relating to the prescribed time for completion, or the current indices or prices whichever is more favorable to the employer, provided that if an extension of time is granted, the above provision shall apply only to adjustments made after the expiry of such extension of time.~~

D) ~~Price variation will be calculated similarly and separately for extra items and / or excess quantities and provisional sums calculated under Sub Clause 10 (b)A (i)&(ii) and Sub Clause 10 (b) B(ii) based on the above formula/formulae in Annexure-I as and when mentioned in Special conditions of contract; IO and WO being the indices applicable to the date on which the rates under Sub Clause 10 (a)A (i)&(ii) and Sub Clause 10 (a) B(iii) are fixed. No price variation shall be admissible for FAIR items created during execution.~~

80. Maximum Price Variation shall be as follows:-

Time Period of Project	Maximum limit of Price Variation-
Up to 12 months	No variation allowed-
Above 12 months to 24 months	5.00%
Above 24 months	10.00%

***Approval of AMC / MC shall be obtained before invitation of tender in case of any changes in above.**

Note:-

- 1) ~~The extension in time period for the projects originally estimated including monsoon results in change of price variation slabs as mentioned above i.e. from first slab to second slab or from second slab to third slab, then the maximum limit of original slab will prevail.~~
- 2) Operative period shall mean original or extended time period of contract.

For example:

Extension of Time period	Maximum Price Variation-
If original period of 11 months including monsoon extends to 16. The operative period will be 11+5 months.	No variation allowed
If original period of 11 months excluding monsoon extends to 16. The operative period will be 11+5 months.	Maximum 5% variation allowed-

Price Variation during Extended Period of Contract:

- i) ~~Extension Due To Modification & Extension for delay due to BMC :-~~

~~The price variation for the period of extension granted shall be limited to the amount payable as per the Indices. In case the indices increases or decreases, above/below the indices applicable, to the last month of the original or extended period vide clause 8 (1) (a) (i) and (ii) of standard GCC~~

- ii) ~~Extension Of Time For Delay Due To Contractor :-~~

~~a) The price variation for the period of extension granted shall be limited to the amount payable as per the Indices in case the indices increase, above the indices applicable, to the last month of the original completion period or the extended period vide above clause 8 (1) (a) (i) and (ii) of standard GCC.~~

~~b) The price variation shall be limited to the amount payable as per the indices, in case the indices decrease or fall below the indices applicable, to the last month of original / extended period of completion period vide above clause 8(1)(b) of standard GCC, then~~

lower indices shall be adopted.

- iii) ~~Extension of Time For Delay due to reasons not attributable to BMC and Contractor (Reference Cl.8 (d) of Standard GCC):~~

~~The price variation for the period of extension granted shall be limited to the amount payable as per the Indices in case the indices increases or decreases, above/below the indices applicable, to the last month of the original period.~~

81. Payment : Terms of payment:

As per Municipal procedure, payment for the work done / material supplied will be made within 30 days of the date from receipt of bill, subject to satisfactory completion of work / delivery of articles as per contract conditions or otherwise as specified in specific conditions of contract.

Interim Payment :-

- i) ~~Interim bills shall be submitted by the Contractor from time to time (but at an interval of not less than one month) for the works executed. The Engineer shall arrange to have the bills verified by taking or causing to be taken, where necessary, the requisite measurement of work.~~
- ii) ~~Payment on account for amount admissible shall be made on the Engineer certifying the sum to which the Contractor is considered entitled by way of interim payment for all the work executed, after deducting there from the amount already paid, the security deposit / retention money and such other amounts as may be deductible or recoverable in terms of the contract.~~
- iii) ~~On request, the contractor will be paid upto 75 percent of the value of the work carried out as an adhoc payment in the first week of next month after deducting there from recoveries on account of advances, interest, retention money, income tax etc. The balance payment due will be paid thereafter.~~
- iv) ~~No interim payment will be admitted until such time the Contractor have fully complied with the requirement of the Condition no.8 (g) and 8 (h) concerning submission and approval of Network Schedule for the works, as detailed in Condition 8 (h). A fixed sum shall be held in abeyance at the time of next interim payment for non-attainment of each milestone in the network and shall be released only on attainment of the said milestone.~~
- v) ~~An interim certificate given relating to work done or material delivered may be modified or corrected by a subsequent interim certificate or by the final certificate. No certificate of the Engineer supporting an interim payment shall of itself be conclusive evidence that any work or materials to which it relates is / are in accordance~~

~~with the contract.~~

82. Banning / De-Registration of Agencies of Construction works / SITC of M&E Works in BMC

The regulations regarding Demotion/ Suspension Banning for specific period or permanently / De-Registration shall be governed as per the respective condition in Contractor Registration Rules of BMC.

83. JOINT VENTURE

In case if Joint Venture is allowed for the Project, the guidelines for JV as follows shall be incorporated in the Tender Document:

- a) Joint Venture should be allowed only when the number of identifiable different works is more than one and/or the estimated cost of tender is more than Rs.100 Crores. JV shall also be allowed for complex technical work below Rs.100 Crores with the approval of concerned AMC
- b) Separate identity/name shall be given to the Joint Venture firm.
- c) Number of members in a JV firm shall not be more than three in normal circumstances, if the work involves only one discipline (say Civil or Electrical). If number of members in JV is required to be more than three, then approval of concerned AMC needs to be sought.
- d) A member of JV firm shall not be permitted to participate either in individual capacity or as a member of another JV firm in the same tender.
- e) The tender form shall be purchased and submitted in the 'name of the JV firm or any constituent member of the JV.
- f) Normally EMD shall be submitted only in the name of the JV and not in the name of constituent member. However, EMD in the name of lead partner can be accepted subject to submission of specific request letter from lead partner stating the reasons for not submitting the EMD in the name of JV and giving written confirmation from the JV partners to the effect that the EMD submitted by the lead partner may be deemed as EMD submitted by JV firm.
- g) One of the members of the JV firm shall be the lead member of the JV firm who shall have a majority (at least 51%) share of interest in the JV firm. The other members shall have a share of not less than 20% each in case of JV firms with up to three members and not less than 10% each in case of JV firms with more than three members. In case of JV firm with foreign member(s), the lead member has to be an Indian firm with a minimum share of 51%.
- h) A copy of Letter of Intent or Memorandum of Understanding (MoU) executed by the JV members shall be submitted by the JV firm along with the tender. The complete details of the members of the JV firm, their share and responsibility in the JV firm etc. particularly with reference to financial technical and other obligation shall be furnished in the agreement.

- i) Once the tender is submitted, the agreement shall not be modified/altere d/terminated during the validity of the tender. In case the tenderer fails to observe/comply with this stipulation, the full Earnest Money Deposit (EMD) shall be forfeited. In case of successful tenderer, the validity of this agreement shall be extended till the currency of the contract expires.
- j) Approval for change of constitution of JV firm shall be at the sole discretion of the BMC. The constitution of the JV firm shall not be allowed to be modified after submission of the tender bid by the JV firm except when modification becomes inevitable due to succession laws etc. and in any case the minimum eligibility criteria should not get viti ated. In any case the Lead Member should continue to be the Lead Member of the JV firm. Failure to observe this requirement would render the offer invalid.
- k) Similarly, after the contract is awarded, the constitution of JV firm shall not be allowed to be altered during the currency of contract except when modification become inevitable due to succession laws etc. and in any case the minimum eligibility criteria should not get viti- ated. Failure to observe this stipulation shall be deemed to be breach of contract with all consequential penal action as per contract condition.
- l) On award of contract to a JV firm, a single Performance Guarantee shall be required to be submitted by the JV firm as per tender conditions. All the Guarantees like Performance Guarantee, Bank Guarantee for Mobilization advance, machinery Advance etc. shall be ac- cepted only in the name of the JV firm and no splitting of guarantees amongst the members of the JV firm shall be permitted.
- m) On issue of LOA, an agreement among the members of the JV firm (to whom the work has been awarded) has to be executed and got registered before the Registrar of the Companies under Companies Act or before the Registrar / Sub-Registrar under the Registration Act, 1908. This agreement shall be submitted by the JV firm to the BMC before signing the contract agreement for the work. (This agreement format should invariably be part of the tender condition). In case the tenderer fails to observe/comply with this stipulation, the full Earnest Money Deposit (EMD) shall be forfeited and other penal actions due shall be taken against partners of the JV and the JV. This joint venture agreement shall have, inter-alia, following clauses:-
- i. **Joint and several liability** - The members of the JV firm to which the contract is award- ed, shall be jointly and severally liable to the Employer (BMC) for execution of the pro- ject in accordance with General and Special conditions of the contract. The JV members shall also be liable jointly and severally for the loss, damages caused to the BMC during the course of execution of the contract or due to no execution of the contract or part thereof.
 - ii. **Duration of the Joint Venture Agreement** -It shall be valid during the entire period of the contract including the period of extension if any and the maintenance period after the work is completed.
 - iii. **Governing Laws** - The Joint Venture Agreement shall in all respect be governed by and interpreted in accordance with Indian Laws.

- iv. **Authorized Member** -Joint Venture members shall authorize one of the members on behalf of the Joint Venture firm to deal with the tender, sign the agreement or enter into contract in respect of the said tender, to receive payment, to witness joint measurement of work done, to sign measurement books and similar such action in respect of the said tender/contract. All notices/correspondences with respect to the contract would be sent only to this authorized member of the JV firm.

No member of the Joint Venture firm shall have the right to assign or transfer the interest right or liability in the contract without the written consent of the other members and that of the employer in respect of the said tender / contract.

n) Documents to be enclosed by the JV firm along with the tender:

- i. In case one or more of the members of the JV firm is/are partnership firm(s), following documents shall be submitted:
- a. Notary certified copy of the Partnership Deed,
 - b. Consent of all the partners to enter into the Joint Venture Agreement on a stamp paper of appropriate value (in original).
 - c. Power of Attorney (duly registered as per prevailing law) in favor of one of the partners to sign the MOU and JV Agreement on behalf of the partners and create liability against the firm.
- ii. In case one or more members is/are Proprietary Firm or HUF, the following documents shall be enclosed:
- a. Affidavit on Stamp Paper of appropriate value declaring that his concern is a Proprietary Concern and he is sole proprietor of the Concern OR he is in position of "KARTA" of Hindu Undivided Family and he has the authority, power and consent given by other partners to act on behalf of HUF.
- iii. In case one or more members is/are limited companies, the following documents shall be submitted:
- a. Notary certified copy of resolutions of the Directors of the Company, permitting the company to enter into a JV agreement, authorizing MD or one of the Directors or Managers of the Company to sign MOU, JV Agreement, such other documents required to be signed on behalf of the Company and enter into liability against the company and/or do any other act on behalf of the company.
 - b. Copy of Memorandum and articles of Association of the Company.
 - c. Power of Attorney (duly registered as per prevailing law) by the Company authorizing the person to do/act mentioned in the para (a) above.
- o)** All the members of the JV shall certify that they have not been black listed or debarred by BMC from participation in tenders/contract in the past either in their individual capacity or the JV firm or partnership firm in which they were members / partners.
- p)** Credentials & Qualifying criteria: Technical and financial eligibility of the JV firm shall be adjudged based on satisfactory fulfilment of the following criteria:

Technical eligibility criteria:

In case of Work involving single discipline, the Lead member of the JV firm shall meet at least 35% requirement of technical capacity as stipulated in tender document.

OR

In case of composite works (e.g. works involving more than one distinct component such as Civil Engineering works, M & E works, Electrical works, etc. and in the case of major bridges, substructure and superstructure etc.), atleast one member should have satisfactorily completed 35% of the value of any one component of the project work so as to cover all the components of project work or any member having satisfactorily completed 35% of the value of work of each component during last seven financial years.

In such cases, what constitutes a component in a composite work shall be clearly defined as part of the tender condition without any ambiguity.

Financial eligibility criteria: The contractual payments received by the JV firm or the arithmetic sum of contractual payments received by all the members of JV firm in any one of the previous three financial years and shall be at least **100% of the estimated value** of the work as mentioned in the tender.

84. Compensation for delay:

If the Contractor fails to complete the works and clear the site on or before the Contract or extended date(s) / period(s) of completion, he shall, without prejudice to any other right or remedy of Municipal Corporation on account of such breach, pay as agreed compensation, amount calculated as stipulated below (or such smaller amount as may be fixed by the Engineer) on the contract value of the whole work or on the contract value of the time or group of items of work for which separate period of completion are given in the contract and of which completion is delayed for every week that the whole of the work of item or group of items of work concerned remains uncompleted, even though the contract as a whole be completed by the contract or the extended date of completion. For this purpose the term 'Contract Value' shall be the value of the work at Contract Rates as ordered including the value of all deviations ordered:

- Completion period for projects (originally stipulated or as extended) not exceeding 6 months : **to the extent of maximum 1 percent per week.**
- Completion period for projects (originally stipulated or as extended) exceeding 6 months and not exceeding 2 years: **to the extent of maximum ½ percent per week.**
- Completion period for projects (originally stipulated or as extended) exceeding 2 years : **to the extent of maximum ¼ percent per week.**

When the delay is not a full week or in multiple of a week but involves a fraction of a week the compensation payable for that fraction shall be proportional to the number of days involved.

Provided always that the total amount of compensation for delay to be paid this condition shall not exceed the undernoted percentage of the Contract Value of the item or group of items of work for which a separate period of completion is given.

- i. Completion period (as originally stipulated or as extended) **not exceeding 6 months: 10 percent.**

- ii) Completion period (as originally stipulated or as extended) exceeding 6 months and not exceeding 2 years : **7½ percent.**
- iii) Completion period (as originally stipulated or as extended) exceeding 2 years : **5 percent.**

The amount of compensation may be adjusted set off against any sum payable to the contractor under this or any other contract with the Municipal Corporation.

85. Action And Compensation Payable In Case Of Bad Work And Not Done As Per Specifications

All works under or in course of execution or executed in pursuance of the contract, shall at all times be open and accessible to the inspection and supervision of the Engineer-in-charge, his authorized subordinates in charge of the work and all the superior officers, officer of the Vigilance Department of the BMC or any organization engaged by the BMC for Quality Assurance and the contractor shall, at all times, during the usual working hours and at all other times at which reasonable notice of the visit of such officers has been given to the contractor, either himself be present to receive orders and instructions or have a responsible agent duly accredited in writing, present for that purpose. Orders given to the Contractor's agent shall be considered to have the same force as if they had been given to the contractor himself.

If it shall appear to the Engineer-in-charge or his authorized subordinates in-charge of the work or to the officer of Vigilance Department, that any work has been executed with unsound, imperfect or unskillful workmanship or with materials of any inferior description, or that any materials or articles provided by him for the execution of the work are unsound or of a quality inferior to that contracted for or otherwise not in accordance with the contract, the contractor shall, on demand in writing which shall be made within twelve months of the completion of the work from the Engineer-in-Charge specifying the work, materials or articles complained of notwithstanding that the same may have been passed, certified and paid for forthwith rectify, or remove and reconstruct the work so specified in whole or in part, as the case may require or as the case may be, remove the materials or articles so specified and provide other proper and suitable materials or articles at his own charge and cost. In the event of the failing to do so within a period specified by the Engineer-in-Charge in his demand aforesaid, then the contractor shall be liable to pay compensation at the same rate as under clause 8.e. of the general condition of contract in section 9 of tender document (for Compensation for delay) for this default. In such case the Engineer-in Charge may not accept the item of work at the rates applicable under the contract but may accept such items at reduced rates as the Engineer in charge may consider reasonable during the preparation of on account bills or final bill if the item is so acceptable without detriment to the safety and utility of the item and the structure or he may reject the work outright without any payment and/or get it and other connected and incidental items rectified, or removed and re-executed at the risk and cost of the contractor. Decision of the Engineer-in- Charge to be conveyed in writing in respect of the same will be final and binding on the contractor.

If the penalisation amount exceeds maximum limit with respect to Clause 8.e of Standard General Conditions of Contract, then a show cause notice shall necessarily be issued to the contract as to why the contract should not be terminated.

The above clause is summarized to make it easy to understand as follows:

- 1 The Engineer-in-charge shall issue notice to the contractor for rectifying the defects or redoing of the work if necessary, within specific time to achieve the desired quality and quantity of the work and this should be governed by clause 8.f and 9.b of Standard General Conditions of Contract.
- 2 If the contractor fails to comply the same, only then, the contractor shall be liable to pay compensation at the same rate as under clause 8.e of the Standard General Condition of Contract (for Compensation for delay) for this default.
- 3 If the penalization amount exceeds the maximum limit, then the contractor will be liable for being banned/ deregistered from business dealings with BMC and this shall be governed by relative provision in Registration Rules of BMC and Standard General Conditions of Contract.
- 4 This penalization shall be levied only on account of delay in work, unsound, imperfect or unskillful workmanship or with materials of any inferior description, or that any materials or articles provided by him for the execution of the work are unsound or of quality inferior to that contracted for or otherwise not in accordance with the contract.

86. Contractors remain liable to pay compensation:

In any case in which any of the powers conferred upon the Engineer In-charge by the **relevant clauses** in documents that form a part of contract as exercised or is exercisable in the event of any future case of default by the Contractor, he is declared liable to pay compensation amounting to the whole of his security deposit. The liability of the Contractor for past and future compensation shall remain unaffected.

In the event of the Executive Engineer taking action against these **relevant clauses**, he may, if he so desires, take possession of all or any tools and plant, materials and stores in or upon the work of site thereof or belonging to the Contractor or procured by him and intended to be used for the execution of the work or any part thereof paying or allowing for the same in account at the contract rates, or in the case of contract rates not being applicable at current market rates to be certified by the Executive Engineer, may after giving notice in writing to the Contractor or his staff of the work or other authorized agent require him to remove such tools and plants, materials or stores from the premises within a time to be specified in such notice and in the event of the Contractor failing to comply with any such requisition, the Executive Engineer may remove them at the contractors expense of sell them by auction or private sell on account of the Contractor at his risk in all respects and certificate of the Executive Engineer as to the expense of any such removal and the amount of the proceeds an expense of any such sell be final and conclusive against the Contractor.

87. No Claim To Any Payment Or Compensation Or Alteration In Or Restriction Of Work

- (a) If at any time after the execution of contract documents, the Engineer shall for any reason whatsoever, desires that the whole or any part of the works specified in the Tender should be suspended for any period or that the whole or part of the work should not be carried out, at all, he shall give to the Contractor a Notice in writing of

such desire and upon the receipt of such notice, the Contractor shall forthwith suspend or stop the work wholly or in part as required after having due regard to the appropriate stage at which the work should be stopped or suspended so as not to cause any damage or injury the work already done or endanger the safety thereof, provided that the decision of the Engineer as to the stage at which the work or any part of it could be or could have been safely stopped or suspended shall be final and conclusive against the contractor.

The Contractor shall have no claim to any payment or compensation whatsoever by reason of or in pursuance of any notice as aforesaid, on account of any suspension, stoppage or curtailment except to the extent specified hereinafter.

- (b) Where the total suspension of Work Order as aforesaid continued for a continuous period exceeding 90 days the contractor shall be at liberty to withdraw from the contractual obligations under the contract so far as it pertains to the unexecuted part of the work by giving 10 days prior notice in writing to the Engineer within 30 days of the expiry of the said period of 90 days, of such intention and requiring the Engineering to record the final measurement of the work already done and to pay final bill. Upon giving such Notice, the Contractor shall be deemed to have been discharged from his obligations to complete the remaining unexecuted work under his contract. On receipt of such notice the Engineer shall proceed to complete the measurement and make such payment as may be finally due to the contractor within a period of 90 days from the receipt of such Notice in respect of the work already done by the contractor. Such payment shall not in any manner prejudice the right of the contractor to any further compensation under the remaining provisions of this clause.
- (c) Where the Engineer required to Contractor to suspend the work for a period in excess of 30 days at any time or 60 days in the aggregate, the Contractor shall be entitled to apply to the Engineer within 30 days of the resumption of the work after such suspension for payment of compensation to the extent of pecuniary loss suffered by him in respect of working machinery remained ideal on the site of on the account of his having an to pay the salary of wages and labour engaged by him during the said period of suspension provided always that the contractor shall not be entitled to any claim in respect of any such working machinery, salary or wages for the first 30 days whether consecutive or in the aggregate or such suspension or in respect of any such suspension whatsoever occasion by unsatisfactory work or any other default on his part, the decision of the Engineer in this regard shall be final and conclusive against the contractor.

88. Contractor to supply plant, ladder, scaffolding, etc and is liable for damages arising from non provision of lights, fencing etc.

The Contractor shall supply at his own cost all material, plant, tools, appliances, implements, ladders, cordage, tackle scaffolding and temporary works requisite or proper for the proper execution of the work, whether, in the original altered or substituted form and whether included in the specification of other documents forming part of the contract or referred to in these conditions or not and which may be necessary for the purpose of satisfying or complying with the requirements of the Eng-In-Charge as to any matter as to which under

these conditions is entitled to be satisfied, or which is entitled to require together with the carriage therefore to and from the work.

The Contractor shall also supply without charge, the requisite number of person with the means and materials necessary for the purpose of setting out works and counting, weighing and assisting in the measurements of examination at any time and from time to time of the work or materials, failing which the same may be provided by the Engineer In-charge at the expense of the contractor and the expenses may be deducted from any money due to the contractor under the contract or from his security deposit or the proceeds of sale thereof, or offers sufficient portion thereof.

The contractor shall provide all necessary fencing and lights required to protect the public from accident and shall also be bound to bear the expenses of defence of every suit, action or other legal proceedings, that may be brought by any person for injury sustained owing to neglect of the above precautions and to pay any damages and cost which may be awarded in any such suit action or proceedings to any such person or which may with the consent of the contractor be paid for compromising any claim by any such person.

89. Prevention of Fire :

The contractor shall not set fire to any standing jungle, trees, brushwood or grass without a written permit from the Engineer In-charge. When such permit is given, and also in all cases when destroying cut or dug up trees brushwood, grass, etc., by fire, the contractor shall take necessary measure to prevent such fire spreading to or otherwise damaging surrounding property. The Contractor shall make his own arrangements for drinking water for the labour employed by him.

90. Compensation for all damages done intentionally or unintentionally by contractor's labour whether in or beyond the limits of BMC property including any damage caused by spreading the fire shall be estimated by the Engineer In-charge or such other officer as he may appoint and the estimate of the Engineer in-charge to the decision of the Dy. Chief Engineer on appeal shall be final and the contractor shall be bound to pay the amount of the assessed compensation on demand failing which the same will be recovered from the Contractor as damages or deducted by the Engineer In-charge from any sums that may be due or become due from BMC to contractor under this Contract or otherwise. Contractor shall bear the expenses of defending any action or other legal proceedings that may be brought to prevent the spread of fire and he shall pay any damages and costs that may be awarded by the Court in consequence.

91. In the case of Tender by partners, any change in the constitution of the firm shall be forthwith, notified by the contractor through the Engineer In-charge for his information.

92. Action where no specifications

In the case of any class of work for which there is no such specifications, such works shall be carried out in accordance with the specifications and in the event of there being no such specifications, then in such case, the work shall be carried out in all respects in accordance with all instructions and requirements of the Engineer In- charge.

93. Safety and medical help :

- (i) The Contractor shall be responsible for and shall pay the expenses of providing medical help to any workmen who may suffer a bodily injury as a result of an accident. If such expenses are incurred by BMC, the same shall be recoverable from the contractor forthwith and be included without prejudice to any other remedy of BMC from any amount due or that may become due to the Contractor.
- (ii) The contractor shall provide necessary personal safety equipment and first-aid box for the use of persons employed on the site and shall maintain the same in condition suitable for immediate use at any time.
- (iii) The workers shall be required to use the safety equipments so provided by the contractor and the contractor shall take adequate steps to ensure the proper use of equipments by those concerned.
- (iv) When the work is carried on in proximity to any place where there is risk or drawing all necessary equipments shall be provided and kept ready for use and all necessary steps shall be taken for the prompt rescue of any person in danger.

94. No compensation shall be allowed for any delay caused in the starting of the work on account of acquisition of land or in the case of clearance of works, on account of ant delay in according to sanction of estimates..

95. Anti-malaria and other health measures:

Anti-Malaria and other health measures shall be taken as directed by the Executive Health Officer of BMC. Contractor shall see that mosquitogenic conditions are created so as to keep vector population to minimum level. Contractor shall carry out anti-malaria measures in the area as per the guidelines issued by the Executive Health Officer of BMC from time to time.

In case of default, in carrying out prescribed anti-malaria measures resulting in increase in malaria incidence, contractor shall be liable to pay BMC on anti- malaria measures to control the situation in addition to fine.

SECTION 10
SPECIFICATIONS &
SELECTION OF MATERIAL

TECHNICAL SPECIFICATIONS

PART A: General Technical specifications :

- 1 The tenderers shall inspect the site prior to submission of their offer, so as to assess the site conditions and other details. No claim on account of ignorance of site condition or adverse site condition, etc. will be entertained during the execution of the work.
- 2 The work shall be carried out as per relevant general requirements and technical specifications etc. of respective item of the B.O.Q. as per B.M.C. Unified Schedule of rates of M&E, BUILDING, HE & ROAD 2023 including list of approved materials etc. All material should be first category of approved list mentioned in Unified Schedule of rates 2023.
4. The technical specifications for the work included in this tender are prepared with care with a view not to create any additional work. However, all the items and works which are required for satisfactory completion and guaranteed performance of the system / projects are deemed to be included in the offer and no extra cost will be paid by B.M.C.
5. Tenderer shall take clearance of BMC at every stage of work and then proceed.
6. The successful tenderer has to make his own arrangement for loading, unloading, transportation and handling of the equipment at the risk and cost of the contractor.
7. The tenderer shall make immediate arrangement for removal of their belongings after the completion of work.
8. The tenderer shall make their own arrangement for security and safety of their staff / labours / materials and other belongings during erection and commissioning work at site. For any mishaps etc. if happened the contractors will be held responsible.
9. The tenderer shall take care & carry out the work in such a way that there will be least disturbance to the working plant & least disruption of electric power supply.
10. The contractor must have facilities to undertake this job including adequate plant & machinery.
11. The work shall be carried out with good workmanship following standard engineering practice.
- 12 All the manpower, machinery and tools etc. required to carry out the work for successful completion of job shall be arranged by contractors only.
13. The contractor shall extend full cooperation and interaction with other agencies at site, if involved.
14. The bill payment shall be done as per work on actual measurement basis.
15. The tenderer shall take photographs with date and time of all hidden items of work before, during and after completion and maintain the photographic records of all the items executed to justify execution of the work at the 'Risk and Cost' of contractors.
- 16 Bhandup Complex is a restricted area , the successful tenderer shall get necessary permits

for his men & vehicles if any prior to commencement of work from Dy.H.E.(B.C.)'s office well in advance by following due procedure.

- 17 The contractor shall issue "Identity Card" to all the work force at site.
- 18 Cost : The Cost quoted should be firm throughout the contract period, which shall also includes loading, unloading, packing and forwarding, transportation, freight, transit insurance etc.
- 19 No escalation in the cost of whatsoever nature will be allowed while execution of these works.
- 20 In case of any dispute the decision of BMC will be final binding to the contractors.
- 21 The Municipal Commissioner does not bind himself to accept the lowest or any tender.
- 22 The Dy. Hydraulic Engineer (Bhandup Complex) reserves right to allow minor variations in the work if BMC is convinced of constraints, if any.

PART B – Technical Specifications

1. Supply, installation, testing and commissioning of submersible type sampling pumps: Quantity : 8 Nos.

Technical details:

a) Pump data -

- i) Type: Vertical submersible type
- ii) Discharge: At least 16 LPM
- iii) Discharge head: 90 lpm at 22 m head to 45 lpm at 52 m head
- iv) Delivery size: 32 mm at least
- v) HP: 1 HP

b) Motor data -

- i) Power supply : 3 phase, 415 VAC +/- 10%, 50Hz +/- 3%
 - ii) HP : 1 HP / 0.75 KW
 - iii) Power cable: Suitable core, copper conductor, flexible, 2.5 sq.mm
PVC insulated, ISI marked, 6.5/1.1 KV grade,
 - iv) Method of starting: DOL
 - v) Rating: Continuous
 - vi) Enclose: IP 65/68 protected
- #### **c) Mechanical construction -**
- i) Pump body: SS 316
 - ii) Impeller: SS 316
 - iii) Shaft : SS 410
 - iv) Coupling : SS 410
 - v) Thrust ring : SS 410
 - vi) Bushing : Gun metal / bronze
 - vii) Mechanical seal TC v/s TC preferred
 - viii) Rubber parts: Nitrile / Viton
 - ix) Fasteners : SS 304

The pump shall conform to IS 14220: 1994 amended up to date. The pump shall be submersible type directly coupled to submersible water filled electric motor with built in anti thrust bearing. The pump set shall be complete with suction strainer, anti-thrust streamlined non return valve and minimum 4 m submersible type copper conductor cable of suitable size. 2 pairs of suitable size 10 mm thick erection/supporting clamps and 1(one) set submersible cable connection kit shall be provided with each pump set as standard accessories. The cost shall be included in the pump cost. Inlet passage of the suction casing shall be designed reduce entry losses and strainer shall be provided in suction casing to restrain large solids entering the pump. For submersible type cables, clamping arrangement and cable guard shall be provided on pump casing. Each metallic impeller shall be dynamically balanced to Grade G 6.3 of IS 11723. The pump characteristic

shall be non overloading type to ensure trouble free operation in the entire operating range. The submersible motor shall conform to IS 9283. The electric motor shall be single phase squirrel cage, water filled submersible type. The motor shall be suitable for operation on 220V (single phase), 50 Hz electric supply with required RPM capable of delivering the rated output.

d) TESTING:

Each pump-motor set shall be factory tested at manufacturer's works as per I.S. 8034 to determine following characteristics covering the full operating range. (i) Head- Discharge curve (ii) Efficiency curve (iii) Dynamic balancing of rotor, impeller

e) CERTIFICATES:

Contractor shall furnish: -Performance characteristic. -Catalogue of pump set and details of pump and its motor. -Manufacturing test certificate, Guarantee card and list of parts for the pump sets. -Operation and maintenance manuals for the pump set.

2. Pump mounting arrangement

- a) Quantity: 8 Nos.
- b) Application: To erect and install the submersible type sampling pumps in the raw water channels.(approx. 1.5 meter depth)
- c) Technical details of the mounting bracket.
 - i) The pump mounting bracket shall be framed as per the reference sketch.
 - ii) 50x50x6mm M.S.angle to hold the pump (Supporting) with the help of flat bars of size 50x6mm thick, SS fasteners/ & anchor bolting on supporting wall.
 - iii) CPVC (SCH.80) pipe of 25mm size shall be connected to delivery of the each pump with suitable reducer, union ,non return valve and ball valve.
 - iv) All M.S. frame work shall be deep galvanized or epoxy painted (with one coat of primer and two coats of epoxy paint.)
 - v) Frame shall be mounted in such way that pump can be easily removed and reinstalled hasselfreely.

3. Laying of CPVC delivery piping

The successful contractor shall install, test and commission the CPVC pipes for raw water sampling pump pretreater stream 'A', 'B', 'C' and 'D' as below -

- a) The CPVC piping from the water sampling pumps to laboratory delivery point shall be laid with required accessories of SCH 80 (Bends, coupling etc.) as shown by B.M.C. site engineer.
- b) CPVC delivery piping for raw water sampling pumps to laboratory delivery point and treated water from old & new MBR to laboratory shall be carried out on the route shown by B.M.C. engineer. If required online tapping shall be provided by the successful contractor from delivery mains of old MBR and new MBR.

- c) The pipes shall be laid by means on existing / new GI trays along walls, on GI Clamps anchored in wall / ceilings of covered trenches, underground, through C class GI conduit of appropriate size (underground) where protection is necessary as per the instructions from B.M.C. engineer.
- d) Underground lying
 - i) The underground installation procedure will cover the trench preparation, piping assembly, lying of pipes and backfilling.
 - ii) The trench bottom shall be min.300mm in depth, continuous, relatively smooth and free of rocks / stones.
 - iii) Soil beddings of 3 to 5 inches underneath piping shall be done.
 - iv) Backfilling should only proceed after all solvent cement joints have been properly cured. The backfill shall be compacted.
 - v) For road crossing CPVC pipes shall laid through suitable size GI C class conduit.
- e) Lying through GI trays
 - i) From pipe junction chamber near administration building to laboratory and locations shown by BMC site engineer the pipes shall be laid in the GI trays in the group.
 - ii) GI trays on wall near sampling pump of raw water shall be used with suitable fixing arrangement.
 - iii) From pipe junction chamber near administration building to laboratory the pipes shall be laid on GI trays in the group.
 - iv) The GI trays shall be firmly grouted in wall by anchor fasteners.
- f) Laying through GI grating covered existing trenches (concealed):
 - i) Cutting of existing welding joints of GI grating before laying of CPVC pipes in trenches.
 - ii) After laying of CPVC pipes, covering the existing GI grating with proper welding as before.

4. Cable:

Supply & laying of ISI mark 1.1KV, Grade PVC, insulated copper conductor armoured cable FRLS outer sheathed- 3C x 2.5mm² size from control panel to SMC for submersible pump set up.

Cable Termination:

Cable Glands

- (i) Double compression type cable glands shall be used. Cable glands shall be brass casting, machine finished and Nickel-plated to avoid corrosion and oxidation. Rubber components used in cable gland shall be of neoprene.
- (ii) For single core cables, gland shall be with brass ring.
- (iii) Cable glands shall be with metric threads.
- (iv) Cable glands shall be conical (& not flange type).

Cable Lugs :-

- (i) Cable lugs shall be of tinned copper, solder less crimping type for cu cables &

AL lugs for the AL cables.

(ii) The current rating of the lugs shall be same as that of the respective cable conductors.

(iii) Ring type cable terminations shall be used.

(iv) Insulated lugs are not acceptable for any cable terminations.

(v) Bi-metal strip/Bi-metallic lug shall be used whenever two different metals are to be connected together.

(vi) Double hole extended neck (long barrel neck) type lugs shall be used in case of cables above 185 sq. Mm.

(vii) Fork terminals shall be used for luminaires & decorative switch/ socket. [Pin terminals may be acceptable during execution only in case other terminals/ lugs cannot be accommodated.

(viii) Reducer / wire pin terminals shall be avoided for MCB terminations. MCB terminations shall be with 'long palm terminals. (ix) All terminations in DBs/ enclosure for earthing & neutral busbars/ terminals shall be with ring type terminals.

(x) All earthing terminations shall be with ring type lugs only.

(xi) All control & interlock cable terminations shall be with ring type lugs. (xii) Anticorrosion/ anti-oxidation compounds shall be used for crimping lugs (This shall especially be ensured for Al cable terminations & any bimetallic terminations (Cu cable termination using tinned copper lugs).

(xiii) If termination is done with crimping tool employing crimping die then forming dies shall be used to make the sector shaped conductor into a round conductor before crimping the lugs on the conductor. The lug must not be crimped directly on the sector conductor.

(xiv) Before crimping the lug, the conductor shall be thoroughly cleaned and special jelly applied over it to prevent further oxidation

5. SMC Junction Box:

The junction box shall be made out of insulating materials such as Sheet Moulding Compound (SMC), ideal for outdoor use. Junction box shall have one piece moulded SMC base and SMC removable type cover or top/side hinged cover as per the requirement of site. Colour of SMC junction box shall be off-white or as approved by site engineer. According to the size of the junction box its thickness shall be 1.5 to 2.5 mm.

6. Catalogues

The tenderer shall upload the detailed technical leaflet / catalogue of the offered sampling pump and CPVC pipes in packet B of the e-tender

S.E.(F.M.)B.C.

A.E.(F.M.)B.C.

E.E.(T.C.W.)B.C.

Pump Mounting Angle frame.

Wall

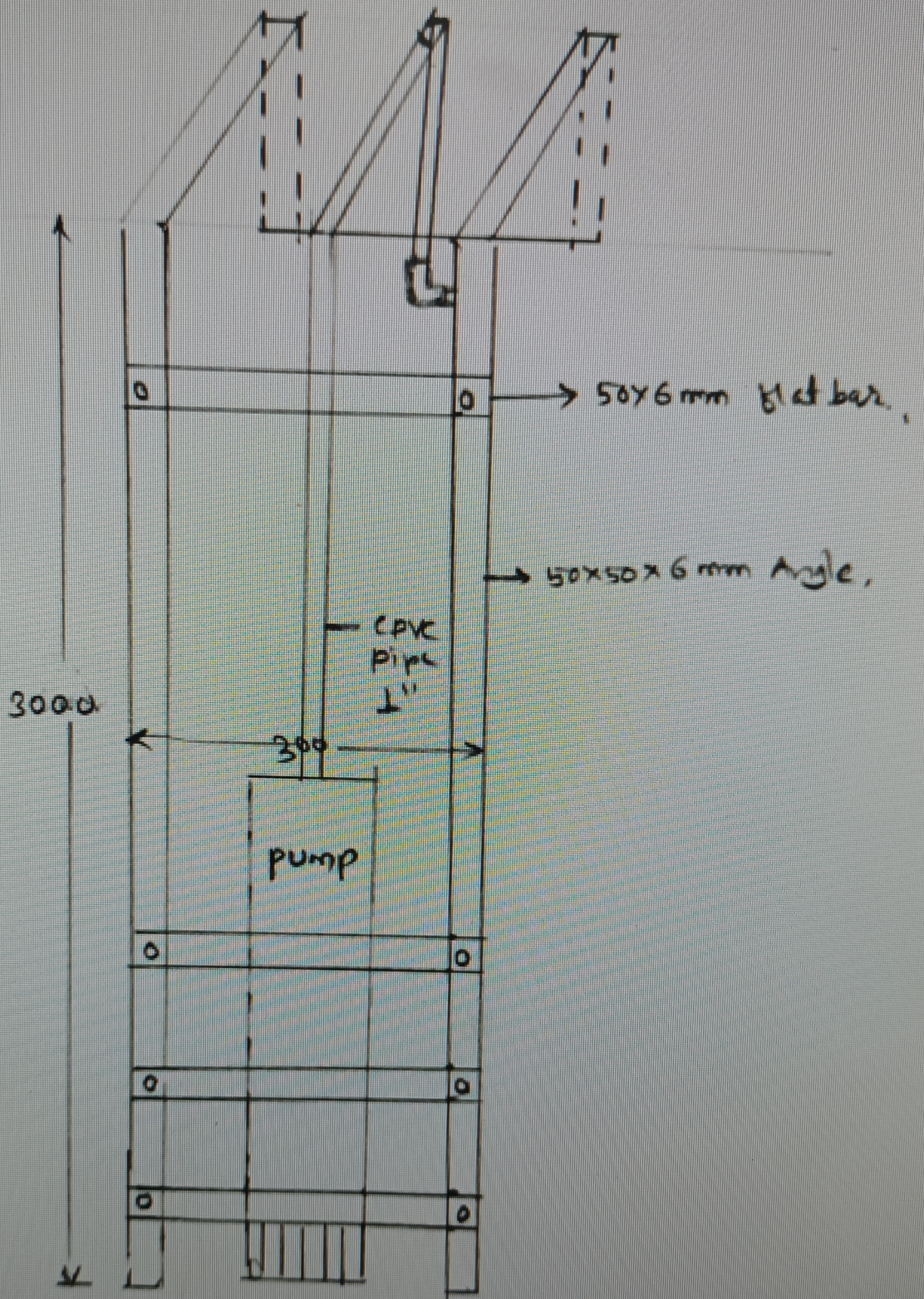

→ 50x6 mm flat bar.

→ 50x50x6 mm Angle.

PVC pipe
1"

3000

300

pump

Qty: 8 Nos.

SELECTION OF MATERIAL

1. ~~All materials brought on the site of work and meant to be used in the same, shall be the best of their respective kinds and to the approval of the Engineer. The Engineer or his representative will accept that the materials are really the best of their kinds, when it is proved beyond doubt that no better materials of the particular kind in question are available in the market.~~
2. ~~The contractor shall obtain the approval of the Engineer of samples of all materials to be used in the works and shall deposit these samples with him before placing an order for the materials with the suppliers. The materials brought on the works shall conform in every respect to their approved samples. Fresh samples shall be deposited with the Engineer whenever the type or source of any material changes.~~
3. ~~The contractor shall check each fresh consignment of materials as it is brought to the site of works to see that they conform in all respects to the Specifications of the samples approved by the Engineer, or both.~~
4. ~~The Engineer will have the option to have any of the materials tested to find out whether they are in accordance with the Specifications and the Contractor will bear all expenses for such testing. All B bills, vouchers and test certificates, which in the opinion of the Engineer or his representative are necessary to convince him as to the quality of the materials or their suitability shall be produced for his inspection when required.~~
5. ~~Any materials that have not been found to conform to the specifications will be rejected forthwith and shall be removed from the site by the contractor at his own cost within 24 hours.~~
6. ~~The Engineer shall have power to cause the Contractors to purchase and use such materials from any particular source, as may in his opinion be necessary for the proper execution of the work.~~
7. ~~Notwithstanding the source, the sand shall be washed using sand washing machine before use.~~

SECTION 11
FRAUD AND CORRUPT
PRACTICES

FRAUD AND CORRUPT PRACTICES

The Applicants and their respective officers, employees, agents and advisers shall observe the highest standard of ethics during the Bidding Process. Notwithstanding anything to the contrary contained herein, the Authority may reject an Application without being liable in any manner whatsoever to the Applicant if it determines that the Applicant has, directly or indirectly or through an agent, engaged in corrupt practice, fraudulent practice, coercive practice, undesirable practice or restrictive practice in the Bidding Process.

Without prejudice to the rights of the Authority under relevant Clause hereinabove, if an Applicant is found by the Authority to have directly or indirectly or through an agent, engaged or indulged in any corrupt practice, fraudulent practice, coercive practice, undesirable practice or restrictive practice during the Bidding Process, such Applicant shall not be eligible to participate in any tender or RFQ issued by the Authority during a period of 2 (two) years from the date such Applicant is found by the Authority to have directly or indirectly or through an agent, engaged or indulged in any corrupt practice, fraudulent practice, coercive practice, undesirable practice or restrictive practice, as the case may be.

For the purposes of this Clause , the following terms shall have the meaning hereinafter respectively assigned to them:

- A. **“corrupt practice”** means the offering, giving, receiving, or soliciting, directly or indirectly, of anything of value to influence the actions of any person connected with the Bidding Process (for avoidance of doubt, offering of employment to, or employing, or engaging in any manner whatsoever, directly or indirectly, any official of the Authority who is or has been associated in any manner, directly or indirectly, with the Bidding Process or the LOA or has dealt with matters concerning the Concession Agreement or arising there from, before or after the execution thereof, at any time prior to the expiry of one year from the date such official resigns or retires from or otherwise ceases to be in the service of the Authority, shall be deemed to constitute influencing the actions of a person connected with the Bidding Process); or save and except as permitted under the relevant sub clause, engaging in any manner whatsoever, whether during the Bidding Process or after the issue of the LOA or after the execution of the Concession Agreement, as the case may be, any person in respect of any matter relating to the Project or the LOA or the Concession Agreement, who at any time has been or is a legal, financial or technical adviser of the Authority in relation to any matter concerning the Project;
- B. **“fraudulent practice”** means a misrepresentation or omission of facts or suppression of facts or disclosure of incomplete facts, in order to influence the Bidding Process ;
- C. **“coercive practice”** means impairing or harming or threatening to impair or harm, directly or indirectly, any person or property to influence any persons participation or action in the Bidding Process;
- D. **“undesirable practice”** means (i) establishing contact with any person connected with or employed or engaged by the Authority with the objective of canvassing, lobbying or in any manner influencing or attempting to influence the Bidding Process; or (ii) having a Conflict of Interest; and

- E. **“Restrictive practice”** means forming a cartel or arriving at any understanding or arrangement among Applicants with the objective of restricting or manipulating a full and fair competition in the Bidding Process.
- F. If the Employer/Financier determines that the Contractor has engaged in corrupt, fraudulent, collusive, coercive or obstructive practices, in competing for or in executing the Contract, then the Employer may, after giving 14 days’ notice to the Contractor, terminate the Contractor's employment under the Contract and expel him from the Site, and the provisions of relevant Clause shall apply as if such expulsion had been made.
- G. Should any employee of the Contractor be determined to have engaged in corrupt, fraudulent, collusive, coercive, or obstructive practice during the execution of the Works, then that employee shall be removed in accordance with relevant Clause.

For the purposes of this Sub-Clause:

- i. “corrupt practice” is the offering, giving, receiving to soliciting, directly or indirectly, of anything of value to influence improperly the actions of another party;
- ii. “another party” refers to a public official acting in relation to the procurement process or contract execution. In this context, “public official” includes Financier staff and employees of other organizations taking or reviewing procurement decisions.
- iii. “fraudulent practice” is any act or omission, including a misrepresentation, that knowingly or recklessly misleads, or attempts to mislead, a party to obtain a financial or other benefit or to avoid an obligation;
- iv. “collusive practice” is an arrangement between two or more parties designed to achieve an improper purpose, including to influence improperly the actions of another party;
- v. “coercive practice” is impairing or harming, or threatening to impair or harm, directly or indirectly, any party or the property of the party to influence improperly the actions of a party;
- vi. “obstructive practice” is deliberately destroying, falsifying, altering or concealing of evidence material to the investigation or making false statements to investigators in order to materially impede the Financier investigation into allegations of a corrupt, fraudulent, coercive or collusive practice; and/or threatening, harassing or intimidating any party to prevent it from disclosing its knowledge of matters relevant to the investigation or from pursuing the investigation; or
- vii. acts intended to materially impede the exercise of the Financier’s inspection and audit rights provided .
- viii. “party” refers to a public official; the terms “benefit” and “obligation” relate to the procurement process or contract execution; and the “act or omission” is intended to influence the procurement process or contract execution.
- ix. ”parties” refers to participants in the procurement process (including public officials) attempting to establish bid prices at artificial, noncompetitive levels.
- x. a “party” refers to a participant in the procurement process or contract execution.

SECTION 12
~~PRE BID MEETING~~

PREBID MEETING

Pre-bid meeting of the interested parties shall be convened at the designated date, time and place. A maximum of three representatives of each Applicant shall be allowed to participate on production of authority letter from the Applicant.

During the course of Pre-bid meeting, the Applicants will be free to seek clarifications and make suggestions for consideration of the Authority. The Authority shall Endeavour to provide clarifications and such further information as it may, in its sole discretion, consider appropriate for facilitating a fair, transparent and competitive Bidding Process.

Interpretation of e-Tender Document:

- a) Tenderer(s) shall examine the tender document and acquaint themselves to all conditions and matters affecting the cost of the works. If any tenderer(s) finds discrepancies or omissions in the Document or if in doubt about their meaning, he should address a query during pre-bid meeting.
- b) Any resulting interpretation of the tender document will be issued to tenderer(s) as an addendum. Verbal clarification obtained from any source shall not be binding on the Corporation.
- c) No tenderer(s) shall amend the text of any document except as may be necessary to comply with any addendum.

Clarification of e-Tendering Documents.

(Pre-bid meeting (If proposed as per e-Tender notice))

The tenderer or his authorized representative is allowed to attend a pre-bid meeting as per the date, time and venue mentioned in the tender notice/header data.

The purpose of the pre-bid meeting will be to clarify issues and to answer questions on any matter that may be raised prior to the pre-bid meeting.

Any tenderer requiring any clarification of the tender document and/or the works may submit his questions in e-mail on dyhebc@yahoo.com to reach Dy H.E. (Bhandup Complex)'s office by Date ~~20.11.2023 till 03.30 p.m.~~

SECTION –13
LIST OF APPROVED BANKS

LIST OF APPROVED BANKS

1. The following Banks with their branches in Greater Mumbai and in suburbs and extended suburbs up to Virar and Kalyan have been approved only for the purpose of accepting Banker's guarantee from 1997-98 onwards until further instructions.
2. The Bankers Guarantee issued by branches of approved Banks beyond Kalyan and Virar can be accepted only if the said Banker's Guarantee is countersigned by the Manager of a branch of the same Bank, within the Mumbai Limit categorically endorsing thereon that said bankers Guarantee is binding on the endorsing Branch of the bank within Mumbai limits and is liable to be enforced against the said branch of the Bank in case of default by the contractor/supplier furnishing the bankers Guarantee.

List of approved Banks:-

A S.B.I. & its subsidiary banks

- 1 State bank of India
- 2 ~~State Bank Of Bikaner & Jaipur~~
- 3 ~~State bank of Hyderabad~~
- 4 ~~State bank of Mysore~~
- 5 ~~State bank of Patiala~~
- 6 ~~State bank of Saurashtra~~
- 7 ~~State bank of Travankore~~

B Nationalized Banks

- 8 Allahbad Bank
- 9 Andhra Bank
- 10 Bank of Baroda
- 11 Bank of India
- 12 Bank of Maharashtra
- 13 Central Bank of India
- 14 Dena Bank
- 15 Indian Bank
- 16 Indian Overseas Bank
- 17 Oriental Bank of Commerce
- 18 Punjab National Bank
- 19 Punjab and Sind Bank
- 20 Syndicate Bank
- 21 Union Bank of India

- 22 United Bank of India
- 23 UCO Bank
- 24 Vijaya Bank
- 24A Corporation Bank

C Scheduled & Commercial Banks

- 25 Bank of Madura Ltd.
- 26 Bank of Rajasthan Ltd.
- 27 Banaras State Bank Ltd.
- 28 Bharat Overseas Bank Ltd.
- 29 Catholic Syrian Bank Ltd.
- 30 City Union Bank Ltd.
- 31 Development Credit Bank
- 32 Dhanalakshmi Bank Ltd.
- 33 Federal Bank Ltd.
- 34 Indusind Bank Ltd.
- 35 ICICI. Banking Corporation Ltd.
- 36 Global Trust Bank Ltd.
- 37 Jammu & Kashmir Bank Ltd.
- 38 Karnataka Bank Ltd.
- 39 Karur Vyasa Bank Ltd.
- 40 Lakshmi Vilas Bank Ltd.
- 41 Nedugundi Bank Ltd.
- 42 Ratnakar Bank Ltd.
- 43 Sangli Bank Ltd.
- 44 South Indian Bank Ltd.
- 45 S.B.I. Corporation & Int. Bank Ltd.
- 46 Tamilnadu Mercantile Bank Ltd
- 47 United Western Bank Ltd.
- 48 Vyasa Bank Ltd.

D Scheduled Urban Co-op Bank

- 49 Abhudaya Co-Op Bank Ltd.
- 50 Bassein Catholic Co-Op Bank Ltd.
- 51 Bharat Co-Op Bank Ltd.
- 52 Bombay merchantile Co-Op Bank Ltd

- 53 Cosmos Co-Op Bank Ltd.
- 54 Greater Mumbai Co-op Bank Ltd.
- 55 Janata Sahakari Bank Ltd.
- 56 Mumbai District Central Co-Op Bank Ltd
- 57 Maharashtra State co-op Bank Ltd.
- 58 New India Co-Op Bank Ltd.
- 59 North Canara GSB.Co-Op Bank Ltd.
- 60 Rupee Co-Op Bank Ltd.
- 61 Sangli Urban Co-Op Bank Ltd.
- 62 Saraswat Co-Op Bank Ltd.
- 63 Shamrao Vithal Co-Op Bank Ltd.
- 64 Mahanagar Co-op.Bank Ltd.
- 65 Citizen Bank Ltd.
- 66 Yes Bank Ltd.

E Foreign Bank

- 67 ABM AMRO (N.Y.) Bank.
- 68 American Express Bank Ltd.
- 69 ANZ Grindlays Bank
- 70 Bank of America N.T. & S.A.
- 71 Bank of Tokyo Ltd.
- 72 Bank Indosuez
- 73 Banque National de Paris
- 74 Barclays Bank
- 75 City bank N.A.
- 76 Hong Kong & Shanghai Banking Corporation
- 77 Mitsui Taiyokobe Bank Ltd.
- 78 Standard Chartered Bank
- 79 Cho-hung Bank

SECTION -14

APPENDIX

FORM OF TENDER

To,
The Municipal Commissioner,
Sir,

I / We have read and examined the following documents relating to the workof

- i. Notice inviting tender.
- ii. Directions to tenderers (General and special)
- iii. General condition of contract for M & E of the BRIHANMUMBAI MUNICIPAL CORPORATION as amended up to date.
- iv. Relevant drawings
- v. Specifications.
- vi. Special directions.
- vii. Annexure A and B.
- viii Bill of Quantity and Rates

- 1A. I / We
(full name in capital letters starting with surname), the proprietor / managing partner / Managing Director / Holder of the business, for the establishment / firm / registered company named herein below, do hereby offer to
..... Referred to in the specifications and schedule to the accompanying form of contract of the rates entered in the schedule of rates sent herewith and signed by me/ us" (strike out the portions which are not applicable).
- 1B. I / We do hereby state and declare that I/We, whose names are given herein below in details with the addresses, have not filled in this tender under any other name or under the name of any other establishment /firm or otherwise, nor are we in any way related or concerned with the establishment / firm or any other person, who have filled in the tender for the aforesaid work."
2. I / We hereby tender for the execution of the works referred to in the aforesaid documents, upon the terms and conditions, contained or referred to therein and in accordance with the specifications designs, drawings & other relevant details in all respects.
- * At the rates entered in the aforesaid Bill of Quantities and Rates.
3. According to your requirements for payment of Earnest Money amounting to Rs. _____ /- (Rs. _____) I/We have deposited the amount through online payment gateways with the C.E. of the Corporation not to bear interest
4. I / We hereby request you not to enter into a contract with any other person/s for the execution of the works until notice of non/acceptance of this tender has first been communicated to me/us, and in consideration of yours agreeing to refrain from so doing I/we agree not to withdraw the offer constituted by this tender before the date of communication to me/us of such notice of non/acceptance, which date shall be not later than ten days from the date of the decision of the Standing Committee or Education Committee of the Corporation, as maybe required under the Mumbai Municipal Corporation Act, not to accept this tender.(Subject to condition 5 below).
5. I/We also agree to keep this tender open for acceptance for a period of 180 days from the date fixed for opening the same & not to make any modifications in its terms & conditions which are not acceptable to the Corporation.

6. I/We agree that the Corporation shall, without prejudice to any other right or remedy, be at liberty to forfeit the said earnest money absolutely, if.
 - a. I / We fail to keep the tender open as aforesaid.
 - b. I / We fail to execute the formal contract or make the contract deposit when called upon to do so.
 - c. I / We do not commence the work on or before the date specified by the Engineer in his work order.
7. I/We hereby further agree to pay all the charges of whatsoever nature in connection with the preparation, stamping and execution of the said contract.
8. ~~I/We further agree that, I/we shall register ourselves as 'Employer' with the Bombay Iron and Steel Labour Board' and fulfill all the obligatory provisions of Maharashtra Mathadi, Hamal and other Manual workers (Regulation of Employment and Welfare) Act 1969 and the Bombay Iron and Steel unprotected workers Scheme 1970.~~
9. "I / We have failed in the accompanying tender with full knowledge of liabilities and, therefore, we will not raise any objection or dispute in any manner relating to any action, including forfeiture of deposit and blacklisting, for giving any information, which is found to be incorrect and against the instructions and directions given in this tender.
10. "I/We further agree and undertake that in the event it is revealed subsequently after the allotment of work/contract to me/us, that any information given by me /us in this tender is false or incorrect, I/We shall compensate the BRIHANMUMBAI MUNICIPAL CORPORATION for any such losses or inconvenience caused to the Corporation in any manner and will not resist any claim for such compensation on any ground whatsoever. I/we agree and undertake that I/we shall not claim in such case any amount by way of damages or compensation for cancellation of the contract given to me/us or any work assigned to me/us or is withdrawn by the Corporation,"

Address

Yours faithfully,

.....

Digital Signature of the Tenderer or the

1.
2.
3.
4.
5.

Full Name and private residential address of all the partners constituting the Firm

- | | |
|---------|----------------|
| 1. | A/c |
| 2. | Name of Bank |
| 3. | |
| 4. | Name of branch |
| 5. | |
| | Vender |

AGREEMENT FORM

Tender / Quotation

Dated 20...

DMC(SE) / AMC(P) / MC's sanction / Standing Committee Resolution No.
..... CONTRACT FOR THE WORKS
.....

This agreement made this day of Two thousand
..... Between
..... of Mumbai, carrying on business
at
..... in Bombay under the style and
name of Messrs. (Hereinafter
called "the contractor" of the one part and
Shri.

the Dy. Municipal Commissioner (Special Engineering) (hereinafter called "the
Commissioner" in which expression are included unless the inclusion is inconsistent
with the context, or meaning thereof, his successor or successors for the time being
holding the office of Dy. Municipal Commissioner (S. E.) of the Second Part and the
BRIHANMUMBAI MUNICIPAL CORPORATION (hereinafter called "the Corporation")
of the third part, WHEREAS the Bidder has tendered for the construction,
completion and maintenance of the works described above and his tender has been
accepted by the Commissioner (with the approval of the standing committee /
Education Committee of the Corporation) NOW THIS AGREEMENT WITNESSETH as
follows :-

- 1) In this agreement words and expressions shall have the same meanings as are
respectively assigned to them in the General Conditions of Contract for works
hereinafter referred to:-
- 2) The following documents shall be deemed to form and be read and constructed as
a part of this agreement viz.
 - a) The letter of Acceptance
 - b) The Bid:
 - c) Addendum to Bid; if any
 - d) Tender Document
 - e) The Bill of Quantities:
 - f) The Specification:
 - g) Detailed Engineering Drawings
 - h) Standard General Conditions of Contracts (GCC)
 - i) All correspondence documents between bidder and BMC
- 3) In consideration of the payments to be made by the Commissioner to the
contractor as hereinafter mentioned the contractor hereby covenants with the
Commissioner to construct, complete and maintain the works in conformity in all
respects with the provision of the contract.

4) The Commissioner hereby covenants to pay to the Contractor in consideration of the construction, completion and maintenance of the works the contract sum, at times and in the manner prescribed by the contract.

IN WITNESS WHERE OF the parties hereto have caused their respective common seals to be herein to affixed (or have hereunto set their respective hands and seals) the day and year above written.

Signed, Sealed and delivered by the contractors

In the presence of

Trading under the name and style of

Full name

Address

Contractors

Signed by Dy. Municipal Commissioner (SE) in the presence of Ex. City/ WS/ ES

Dy. Municipal Commissioner (SE)

The common seal of the BRIHANMUMBAI MUNICIPAL CORPORATION was hereunto affixed on the 2019 in the presence of two members of the standing committee.

- | | |
|----|----|
| 1. | 1. |
| 2. | 2. |

And in the presence of the Municipal Secretary

Municipal Secretary

Note: The successful bidder will have to pay for preparing contract documents, legal charges, stamp duty and stationery charges as mentioned in section 6

ANNEXURE " A "

Name of work : Providing new sampling points at Bhandup Complex

1. The Engineer for this work: Hydraulic Engineer
Dy. Hydraulic Engineer (Bhandup Complex)
Exe. Eng. (T.C.W.) B.C.

2. Estimated cost of Tender:

Sr. No.	Description of work	Total Amount Rs.
1	Civil Work	
2	Mecanical/Electrical Work	Rs.19,92,310/-
3	Total Amount	
3.	Earnest Money (1% of the Estimated cost)	Rs.20000.00
4.	Contract Period : 4 Months (Excluding Monsoon)	
5.	Free Maintenance period or Guarantee period : 3 Years	
6.	Security Deposit	
a)	Contract Deposit:	2 % of contract sum (including 4% physical contingencies, if any) + Performance Guarantee as mentioned on Page 40
b)	Retention Money:	Not Applicable

(Signature of Tender issuing officer)

Signature of authorized person of company

ANNEXURE " B "

(On Rs. 500/- Stamp Paper)

PRE-CONTRACT INTEGRITY PACT

The Bidder commits himself to take all measures necessary to prevent corrupt practices, unfair means and illegal activities during any stage of his bid or during any pre-contract or post-contract stage in order to secure the contract or in furtherance to secure it and in particular commits himself to the following:-

1. The Bidder will not offer, directly or through intermediaries, any bribe, gift, consideration, reward, favour, any material or immaterial benefit or other advantage, commission, fees, brokerage or inducement to any official of the BMC, connected directly or indirectly with the bidding process, or to any person, organization or third party related to the contract in exchange for any advantage in the bidding, evaluation, contracting and implementation of the Contract.
2. The Bidder further undertakes that he has not given, offered or promised to give, directly or indirectly any bribe, gift, consideration, reward, favour, any material or immaterial benefit or other advantage, commission, fees, brokerage or inducement to any official of the BMC or otherwise in procuring the Contract or forbearing to do or having done any act in relation to the obtaining or execution of the Contract or any other Contract with the Government for showing or forbearing to show favour or disfavour to any person in relation to the Contract or any other Contract with the Government.
3. The Bidder will not collude with other parties interested in the contract to impair the transparency, fairness and progress of the bidding process, bid evaluation, contracting and implementation of the contract.
4. The Bidder will not accept any advantage in exchange for any corrupt practice, unfair means and illegal activities.
5. The Bidder, either while presenting the bid or during pre-contract negotiations or before signing the contract, shall disclose any payments he has made, is committed to or intends to make to officials of the BMC or their family members, agents, brokers or any other intermediaries in connection with the contract and the details of services agreed upon for such payments.
6. The Bidder shall not use improperly, for purposes of competition or personal gain, or pass on to others, any information provided by the BMC as part of the business relationship, regarding plans, technical proposals and business details, including information contained in any electronic data carrier. The Bidder also undertakes to exercise due and adequate care lest any such information is divulged.

7. The Bidder commits to refrain from giving any complaint directly or through any other manner without supporting it with full and verifiable facts.
8. The Bidder shall not instigate or cause to instigate any third person to commit any of the actions mentioned above.
9. The Bidder and their respective officers, employees, agents and advisers shall observe the highest standard of ethics during the Bidding Process. Notwithstanding anything to the contrary contained herein, the Authority may reject an Application without being liable in any manner whatsoever to the Applicant if it determines that the Applicant has, directly or indirectly or through an agent, engaged in corrupt practice, fraudulent practice, coercive practice, undesirable practice or restrictive practice in the Bidding Process

For the purposes of this Clause 9, the following terms shall have the meaning herein after respectively assigned to them:

1. “fraudulent practice” means a misrepresentation or omission of facts or suppression of facts or disclosure of incomplete facts, in order to influence the Bidding Process ;
2. “coercive practice” means impairing or harming or threatening to impair or harm, directly or indirectly, any person or property to influence any persons participation or action in the Bidding Process;
3. “undesirable practice” means (i) establishing contact with any person connected with or employed or engaged by the Authority with the objective of canvassing, lobbying or in any manner influencing or attempting to influence the Bidding Process; or (ii) having a Conflict of Interest; and
4. “restrictive practice” means forming a cartel or arriving at any understanding or arrangement among Applicants with the objective of restricting or manipulating a full and fair competition in the Bidding Process.

Signature of Tenderer /
Bidder

Annexure- C

(On Rs. 500/- Stamp Paper)

DECLARATION CUM INDEMNITY BOND

I, of, do hereby declared and undertake as under.

1. I declare that I have submitted certificates as required to Executive engineer (Monitoring) at the time of registration of my firm / company and there is no change in the contents of the certificates that are submitted at the time
2. I declare that I in capacity as Manager / Director / Partners / Proprietors of has not been charged with any prohibitory and /or penal action such as banning (for specific time or permanent) / de-registration or any other action under the law by any Government and / or Semi Government and / or Government undertaking.
3. I declare that I have perused and examined the tender document including addendum, condition of contract, specifications, drawings, bill of quantity etc. forming part of tender and accordingly, I submit my offer to execute the work as per tender documents at the rates quoted by me in capacity as of
4. I further declare that if I am allotted the work and I failed to carry out the allotted work in accordance with the terms and conditions and within the time prescribed and specified, BMC is entitled to carry out the work allotted to me by any other means at my risk and cost, at any stage of the contract.
5. I also declare that I will not claim any charge/damages/compensation for non availability of site for the contract work at any time.
6. I declare that I will positively make the arrangements of the required equipment on the day of commencement or with respect to the progress of the work in phases, as per the instructions of site in charge.

Signature of Tenderer /
Bidder

~~—BANKER'S GUARANTEE IN LIEU OF CONTRACT DEPOSIT~~

~~THIS INDENTURE made this _____ day of _____ BETWEEN THE _____ BANK incorporated under the English / Indian Companies Acts and carrying on business in Mumbai (hereinafter referred to as 'the bank' which expression shall be deemed to include its successors and assigns) of the first part _____ inhabitants carrying on business at _____ in Mumbai under the style and name of Messer's _____ (hereinafter referred to as 'the consultant') of the second part Shri. _____ THE MUNICIPAL COMMISSIONER FOR GREATER MUMBAI (hereinafter referred to as 'the commissioner' which expression shall be deemed, also to include his successor or successors for the time being in the said office of Municipal Commissioner) of the third part and THE BRIHANMUMBAI MUNICIPAL CORPORATION (hereinafter referred to as 'the Corporation') of the fourth part WHEREAS the consultants have submitted to the Commissioner tender for the execution of the work of " _____ and the terms of such tender / contract require that the consultants shall deposit with the Commissioner as / contract deposit / earnest money and / or the security a sum of Rs. _____ (Rupees _____)~~

~~AND WHEREAS if and when any such tender is accepted by the Commissioner, the contract to be entered into in furtherance thereof by the consultants will provide that such deposit shall remain with and be appropriated by the Commissioner towards the Security deposit to be taken under the contract and be redeemable by the consultants, if they shall duly and faithfully carry out the terms and provisions of such contract and shall duly satisfy all claims properly chargeable against them there under AND WHEREAS the consultants are constituents of the Bank and in order to facilitate the keeping of the accounts of the consultants, the Bank with the consent and concurrence of the consultants has requested the Commissioner to accept the undertaking of the Bank hereinafter contained, in place of the contractors depositing with the Commissioner the said sum as earnest money and /or security as aforesaid AND WHEREAS accordingly the Commissioner has agreed to accept such undertaking.~~

~~NOW THIS AGREEMENT WITNESSES that in consideration of the premises, the Bank at the request of the consultants (hereby testified) UNDERTAKES WITH the commissioner to pay to the commissioner upon demand in writing, whenever required by him, from time to time, so to do, a sum not exceeding in the whole Rs. _____ (Rupees _____) under the terms of the said tender and / or the contract. The B.G. Is valid upto _____.~~

~~—"Notwithstanding anything what has been stated above, our liability under the above guarantee is restricted to Rs. only and guarantee shall remain in force up to unless the demand or claim under this guarantee is made on us in writing on or before all your right under the above guarantee shall be forfeited and we shall be released from all liabilities under the guarantee thereafter"~~

~~IN WITNESS WHEREOF-~~

~~WITNESS (1) _____~~

~~Name and _____~~

~~address _____~~

~~WITNESS (2) _____~~

~~Name and _____ the duly constituted Attorney Manager~~

~~address _____~~

~~the Bank and the said Messer's _____~~

~~_____ (Name of the Bank)~~

~~WITNESS (1) _____~~

~~Name and _____~~

~~address _____~~

~~WITNESS (2) _____~~

~~Name and address _____~~

~~For Messer's _____~~

~~address _____~~

~~have here into set their respective hands the day and year first above written.~~

~~The amount shall be inserted by the Guarantor, representing the Contract Deposit in Indian Rupees.~~

Annexure - D
Undertaking for best price

(On stamp paper of Rs. 500/- duly notarized by notary with red seal and registration number)

Tender / Bid No. _____

To,
The Municipal Commissioner
For Brihanmumbai Municipal Corporation

Sir ,

“I / We(Full Name in capital letters starting with surname) , the Proprietor / Managing Partner / Managing Director / Holder of the Business / Manufacturer / Authorized Dealer, for the establishment / firm / registered company , named herein below , do hereby , state and declare that I/We ----- whose names are given herein below in details with the addresses have not filled in this tender under any other name or under the name of any other establishment / firm or otherwise , nor are We in any way related or concerned with any establishment / firm or any other person , who have filled in the tender for the aforesaid work.”

“ I / We do hereby further undertake that, we have offered the best prices for the subject supply / work as per the present market rates. **Further, we do here by undertake and commit that we have not offered / supplied the subject product / similar product / system or sub system in the past one year in the Maharashtra State for quantity variation up to - 50% or + 10 % at a price lower than that offered in the present bid to any other outside agencies including Govt. / Semi Govt. agencies and within the BMC also.** Further, we have filled in the accompanying tender with full knowledge of the above liabilities and therefore we will not raise any objection or dispute in any manner relating to any action, including forfeiture of deposit and blacklisting, for giving any information which is found to be incorrect and against the instructions and directions given in this behalf in this tender.

I / We further agree and undertake that in the event it is revealed subsequently after the allotment of work / contract to me / us , that any information given by me / us in this tender is false or incorrect , I / We shall compensate the Brihanmumbai Municipal Corporation for any such losses or inconvenience caused to the Corporation in any manner and will not resist any claim for such compensation on any ground whatsoever , I / We agree and undertake that I / We shall not claim in such case any amount , by way of damages or compensation for cancellation of the contract given to me / us or any work assigned to me / us or is withdrawn by the Corporation.”

Signature of Tenderer/Bidder

Annexure - E

Rate Analysis

Item Description

Sr. No.	Description of rate analysis parameters	Unit	Quantity	Rate	Amount
1	Basic Material (Rate should be inclusive of all taxes)				
2	Machinery Hire Charges				
3	Labour Type		(Labour components)		
4	Total of all components				
5	Overhead & Proffit 15% on 4				
6	Total Rate (4 + 5)				
7	Per unit rate				

Sign & Seal of the Tenderer

Annexure - F
Irrevocable Undertaking
Bid No.

(On Rs.500/- Stamp Paper)

I Shri / Smt. ----- aged ----- years Indian Inhabitant. Proprietor / Partner/
Director of M/s----- resident at ----- do hereby
given Irrevocable undertaking as under;

- i) I say & undertake that as specified in section 171 of CGST Act 2017, any reduction in rate of tax on supply of goods or services or the benefit of input tax credit shall be mandatorily passed on BMC by way of commensurate reduction in prices.
- ii) I further say and undertake that I understand that in case the same is not passed on and is discovered at any later stage, BMC shall be at liberty to initiate legal action against me for its recovery including, but not limited to an appeal to the Screening Committee of GST Counsel.
- iii) I say that above said irrevocable undertaking is binding upon me/ my Partners/company/ other directors of the company and also upon my/our legal heirs, assignee, Executor, administrator etc.
- iv) If I fails to compliance with the provisions of the GST Act, I shall be liable for penalty/punishment or both as per the provisions of GST Act.

Whatever has been stated here in above is true & correct to my/our own knowledge& belief.

Solemnly affirmed at

DEPONENT

This day of
ME

BEFORE

Interpreted Explained and Identified by me.

PROFORMAS

PROFORMA- I

The list of similar works as stated in para 'A' of Post qualification during last five years –

PROFORMA- I

Sr. No.	Name of the Project	Name of the employer	Stipulated date of completion	Actual date of completion	Actual Cost of work done
1	2	3	4	5	6

NOTE:

- j. Scanned Attested copies of completion / performance certificates from the Engineer-in-Charge for each work should be annexed in the support of information furnished in the above proforma.
- k. Works shall be grouped financial year-wise.

PROFORMA- II

Yearly turnover of Civil Engineering Construction Works during the last five years.

PROFORMA- II

Sr. No.	Financial year	Annual Turnover of Civil Engineering Works	Updated value to current year	Average of last 5 years	Page No.
1					
2					
3					
4					
5					
Total					

NOTE: The above figures shall tally with the audited balance sheets uploaded by the tenderers duly certified by Chartered Accountant.

PROFORMA- III

At least similar work, as stated in para 'A' of Post qualification,.

PROFORMA- III

Name of the Project	Name of the Employer	Cost of the Project	Date of issue of work Order	Stipulated Date of Completion	Actual Date of Completion	Actual cost of work done	Remarks explaining reasons for delay, if any
1	2	3	4	5	6	7	8

Note: Scanned Attested copies of completion/performance certificates from the Engineer-in-charge for each work should be annexed in support of information furnished in the above proforma.

PERSONNEL:

PROFORMA- IV

Sr. No.	Post	Name (Prime Candidate / Alternative)	Qualification	Work Experience	
				No. of Years	Name of Project
1	Project Manager				
2	Quality Control Engineer				
3	Site Engineer				

4	Site Supervisor			
---	-----------------	--	--	--

Note : Scanned Attested copies of qualification certificates and details of work ex- perience shall be submitted / uploaded.

PROFORMA- V

MACHINERY: (for special work only)

PROFORMA- V / A

Sr. No.	Equipment	Number	Owned / Leased / Assured access
1	2	3	4

PROFORMA- V / B

Sr. No.	Equipment	Number	Owned
1	2	3	4

Note: The tenderer(s) shall furnish/upload the requisite Scanned Attested documents of ownership/leased of machineries. The undertaking from the suppliers will not be accepted.

PROFORMA- VI / A

Details of Existing Commitments and ongoing works –

PROFORMA- VI / A

Description of work	Place	Contract No. & Date	Name & Addresses of employer	Value of Contract in Rs.	Schedule	Value of work remaining to be completed	Anticipated Date of completion
1	2	3	4	5	6	7	8

Note: Scanned Attested copies of completion/performance certificates from the Engineer in Charge for each work should be annexed in the support of information furnished in the above proforma.

PROFORMA- VI / B

Details of works for which bids are already uploaded –

PROFORMA- VI / B

Description of work	Place	Name & Addresses of employer	Value of Contract in Rs.	Time	Date on which decision is expected	Remarks
1	2	3	4	5	6	7

Note: Scanned Attested copies of certificates from the Engineer-in-charge for each work shall be annexed.

PROFORMA IX

Information on Litigation History in which the tenderer is involved.

<i>Other Party (ies)</i>	<i>Employer</i>	<i>Cause of Dispute</i>	<i>Amount involved</i>	<i>Remarks showing Present Status.</i>
1	2	3	4	5

Note: Scanned Attested copies of completion/performance certificates from the Engineer-in-charge for each work should be annexed and uploaded.

PROFORMA – X

Information of certificate issuing authorities

Sr. No.	Employer/Name of issuing Authority	Designation of issuing Authority	E-mail ID of issuing Authority	Contact numbers of issuing Authority
1	2	3	4	5

Annexure “G”

Undertaking for Conversant to all sites

(on Rs.500/-Stamp Paper)

Bid no. :

We _____ hereby give the undertaking, that we have inspected the site personally and understood the nature and quantum of work. We are conversant to onsite situation and difficulty and accordingly bid is submitted.

TENDERER’S FULL SIGNATURE
WITH FULL NAME & RUBBER STAMP

ANNEXURE-I
GRIEVANCE REDRESSAL MECHANISM

BMC has formed a Grievance Redressal Mechanism for redressal of bidder's grievances. Any Bidder or prospective Bidder aggrieved by any decision, action or omission of the procuring entity being contrary to the provisions of the tender or any rules or guidelines issued therein, in Packet 'A', 'B' & 'C' can make an application for review of decision of responsiveness in Packet 'A', 'B' & 'C' within a period of 7 days or any such other period, as may be specified in the Bid document.

While making such an application to procuring entity for review, aggrieved bidders or prospective bidders shall clearly specify the ground or grounds in respect of which he feels aggrieved.

Provided that after declaration of a bidder as a successful in Packet 'A' (General Requirements), an application for review may be filed only by a bidder who has participated in procurement proceedings and after declaration of successful bidder in Packet 'B' (Technical Bid), an application for review may be filed only by successful bidders of Packet 'A'. Provided further that, an application for review of the financial bid can be submitted, by the bidder whose technical bid is found to be acceptable/ responsive.

Upon receipt of such application for review, BMC may decide whether the bid process is required to be suspended pending disposal of such review. The BMC after examining the application and the documents available to him, give such reliefs, as may be considered appropriate and communicate its decision to the Applicant and if required to other bidders or prospective bidders, as the case may be.

BMC shall deal and dispose off such application as expeditiously as possible and in any case within 10 days from the date of receipt of such application or such other period as may be specified in pre-qualification document, bidder registration document or bid documents, as the case may be.

Where BMC fails to dispose off the application within the specified period or if the bidder or prospective bidder feels aggrieved by the decision of the procuring entity, such bidder or prospective bidder may file an application for redressal before the "Internal Procurement Redressal Committee" within 7 days of the expiry of the allowed time or of the date of receipt of the decision, as the case may be. Every such application for internal redressal before Redressal Committee shall be accompanied by fee of Rs.25,000/- and fee shall be paid in the form of D.D. in favour of M.C.G.M.

1st Appeal by the bidder against the decision of C.E./ HOD/ Dean can be made to concerned DMC/ Director who should decide appeal in 7 days.

If not satisfied, 2nd Appeal by the bidder can be made to concerned A.M.C. for decision.

Grievance Redressal Committee (GRC) is headed by concerned D.M.C/ Director of parucuar department for the first appeal/ grievances by the bidder against the decision for responsiveness / non- responsiveness in Packet 'A', Packet 'B' or Packet 'C' and if not satisfied, concerned A.M.C. will take decision as per second appeal made by the bidder.

This Grievance Redressal Committee (GRC) will be operated through DMC (CPD) office where appeals of aggrieved bidder will be received with fee of Rs. 25,000/- from aggrieved bidder. The necessary correspondence in respect of said applications to the aggrieved bidder & concerned department, issuing notices, arranging of Grievance Redressal Committee (GRC) with D.M.C. and further proceeding will be carried out through registrar appointed by MCGM.

No application shall be maintainable before the redressal Committee in regard of any decision of the BMC relating to following issues:

Determination of need of procurement

The decision of whether or not to enter into negotiations.

Cancellation of a procurement process for certain reasons.

On receipt of recommendation of the Committee, It will be communicate his decision thereon to the Applicant within 10 days or such further time not exceeding 20 days, as may be considered necessary from the date of receipt of the recommendation and in case of non-acceptance of any recommendation, the reason of such non-acceptance shall also be mentioned in such communication.

Additional Municipal Commissioner and/or Grievance Redressal Committee, if found, come to the conclusion that any such complaint or review is of vexatious, frivolous or malicious nature and submitted with the intention of delaying or defeating any procurement or causing loss to the procuring entity or any other bidder, then such complainant shall be punished with fine, which may extend to Five Lac rupees or two percent of the value of the procurement, whichever is higher.

Full Signature of the tenderer
with Official Seal and Address.

ANNEXURE-J

(On Rs. 500/- Stamp Paper)

DECLARATION REGARDING LITIGATION & ARBITRATION HISTORY

Undertaking for the tender of contract “Providing new sampling points at Bhandup Complex ”

I, Proprietor of
M/s., having office at
.....
.....
....., do hereby declared and undertake as under:

I undertake that, I or my company M/s. have not been charged with any prohibitory and / or penal action such as banning for specific time or permanent / deregistration or any other action under the law by any government and / or Semi Government and / or Government undertaking.

I undertake that, I or my company M/s. have not been framed for any kind of litigation and we do not have any kind of arbitration history against us.

**TENDERER’S FULL SIGNATURE
WITH FULL NAME & RUBBER STAMP**